

05247800 - LT-A ST25 D40 C12 SEC-SP H90

Type	LT-A ST Slotting tool 90°
Mounting	CYLINDRICAL SHANK 40
Tool output	Tool diameter 12
Coolant	External coolant
Max speed [rpm]	700
Max torque [Nm]	17.5
Ratio	1:1
Y axis adjustment	NO
Feed pushing [N]	1000
Stroke [mm]	25
Work stroke [mm]	20
H [mm]	90
Accessories	N.A.
Notes	N.A.
Mounting tips	Not suitable for every application, please check

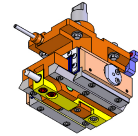

Always check live tool dimensions on the turret

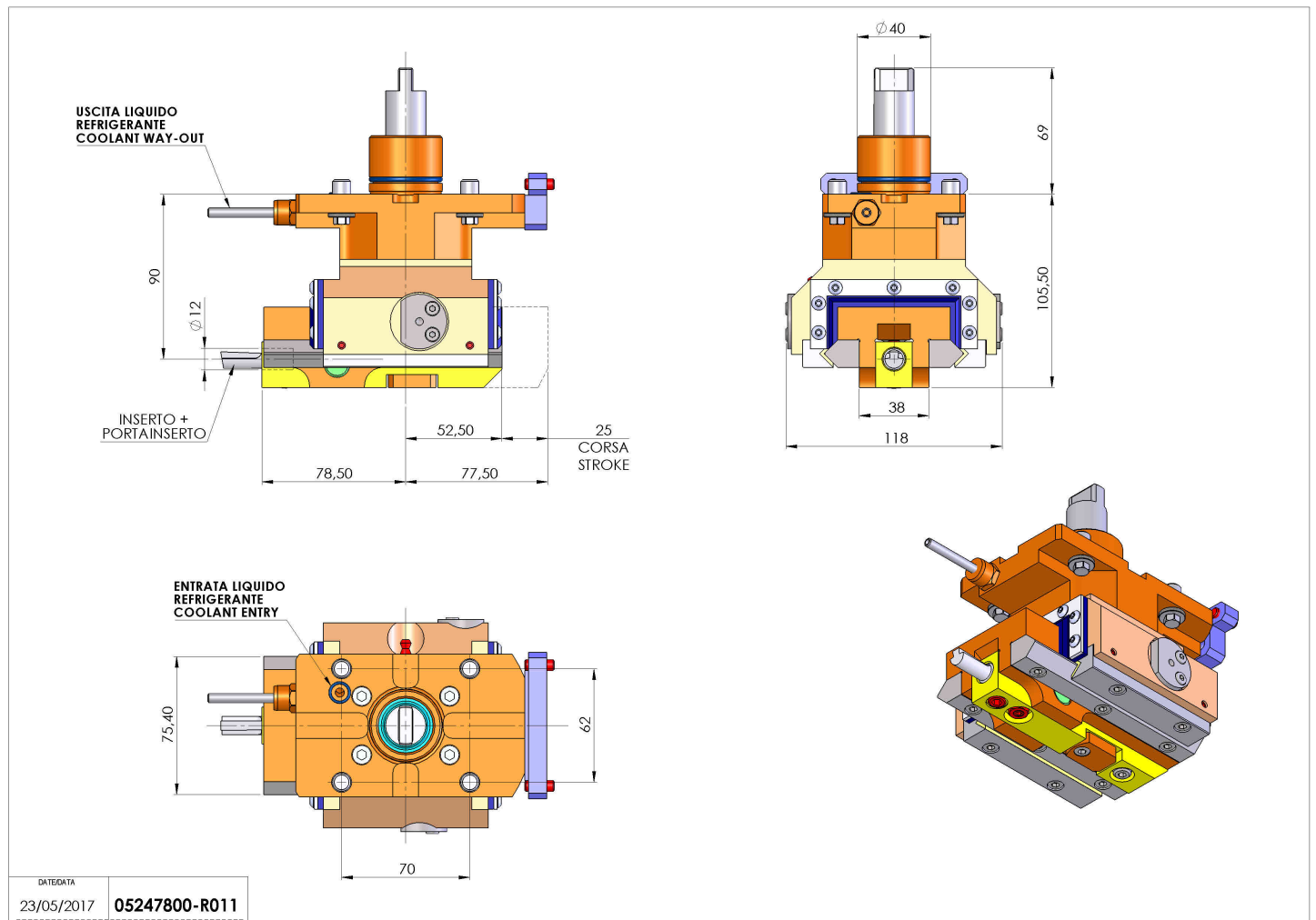

DATE/DATE: 23/05/2017
05247800-R011

Subject to technical changes