

05247400 - LT-S D40 ER25F OF90 HRF HS H82

Type	LT-S OFS Tool holder straight offset
Mounting	CYLINDRICAL SHANK 40
Tool output	Collet nut ER 25 F - internal nut
Coolant	HP Internal coolant
Offset [mm]	90
Direction of rotation	r1 ↻ r2 ↻
Max speed [rpm]	12000
Max torque [Nm]	40
Ratio	1:1
H [mm]	81,5
Max pressure [bar]	80
Accessories	N.A.
Notes	N.A.
Mounting tips	Not suitable for every application, please check

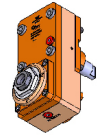

Always check live tool dimensions on the turret

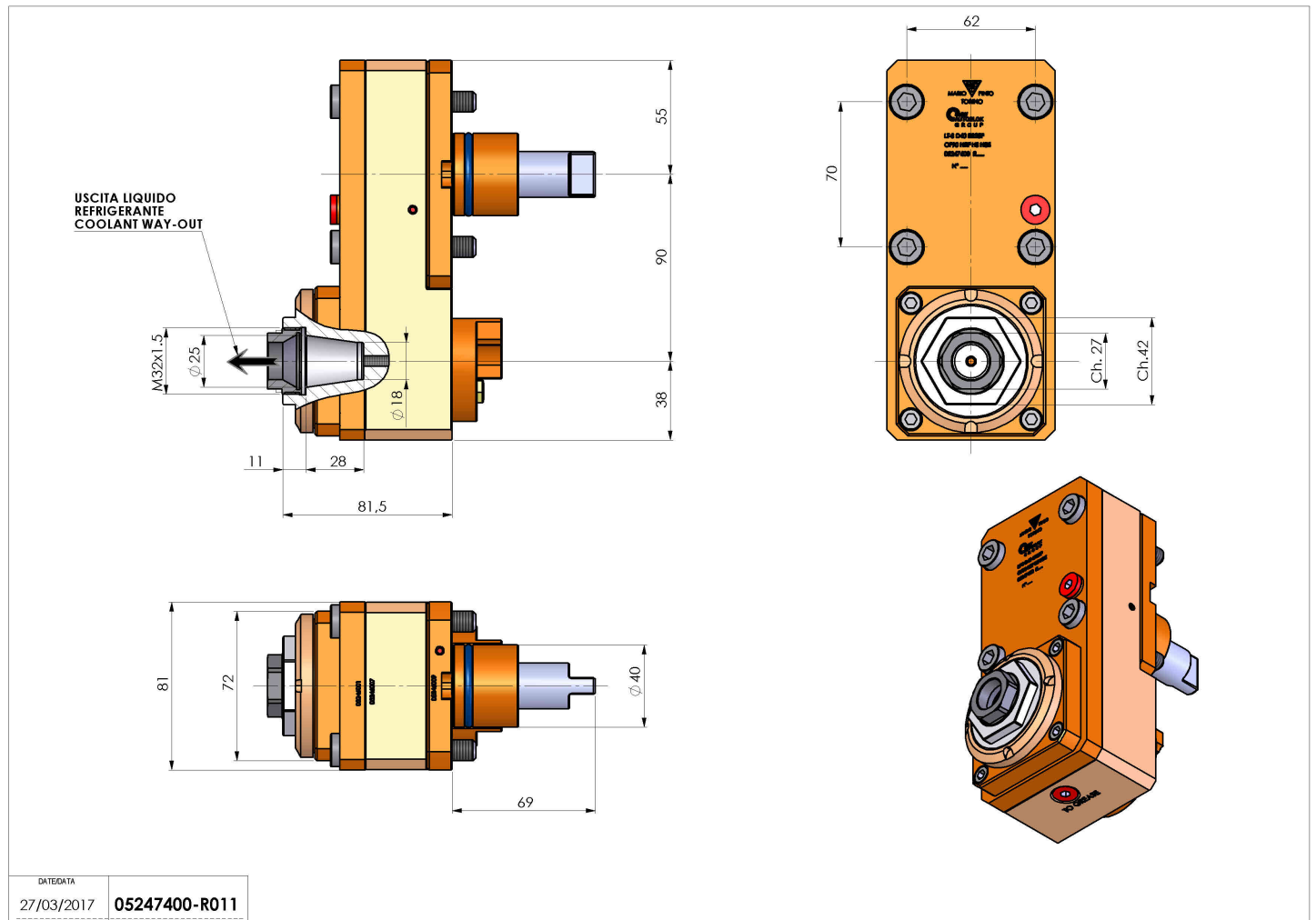

DATE/DATE	05247400-R011
27/03/2017	

Subject to technical changes