

05234700 - LT-S BMT75EM OFS95 ER40F 2:1 H108

Type	LT-S OFS Tool holder straight offset
Mounting	BMT 75 EM
Tool output	Collet nut ER 40 F - internal nut
Coolant	External coolant
Offset [mm]	95
Direction of rotation	r1 ↻ r2 ↻
Max speed [rpm]	in 6000 / out 3000
Max torque [Nm]	in 60 / out 120
Ratio	2:1
H [mm]	108
Accessories	N.A.
Notes	N.A.
Mounting tips	Not suitable for every application, please check

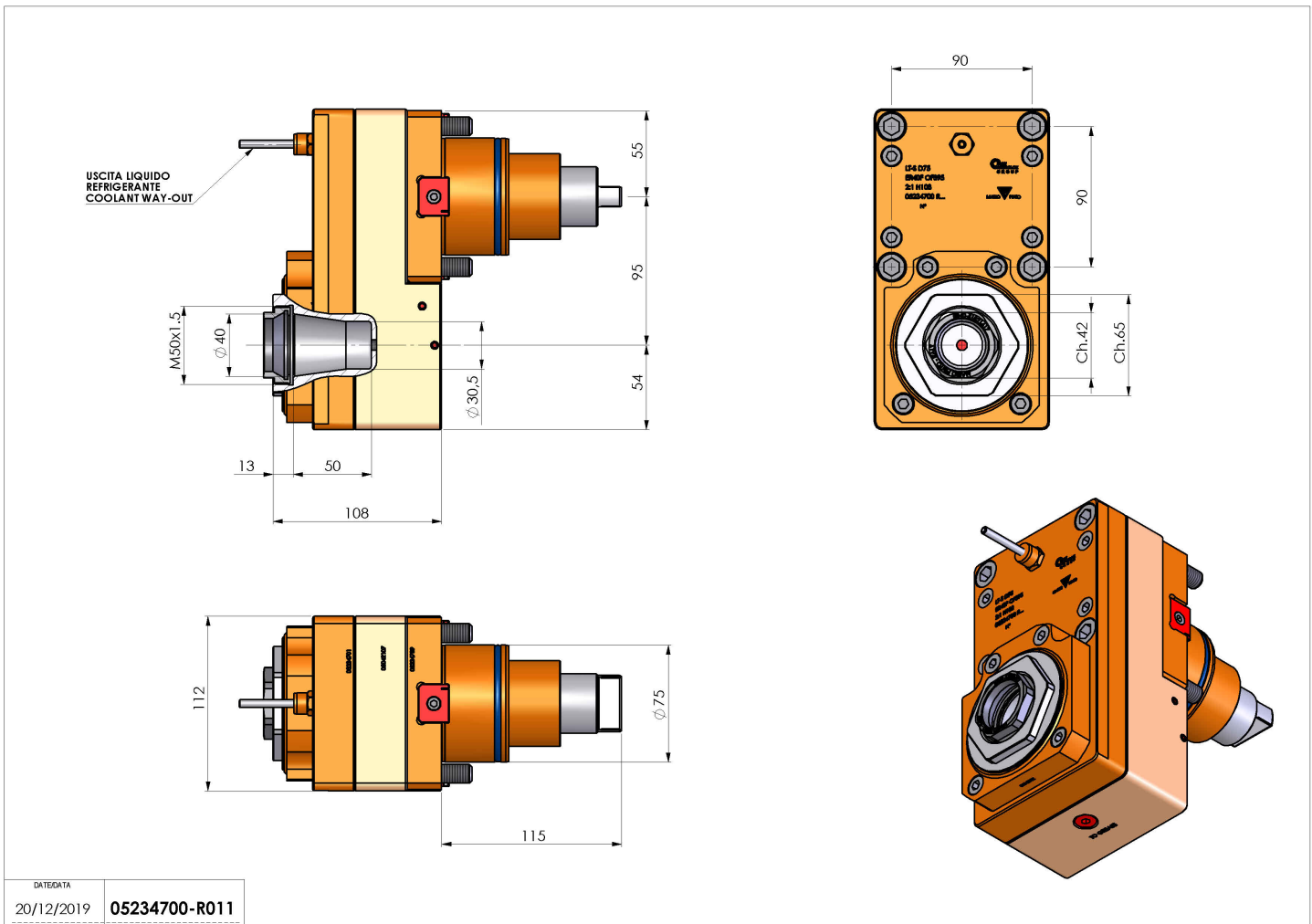

Always check live tool dimensions on the turret



DATE/DATE	05234700-R011
20/12/2019	

Subject to technical changes