

## 05231200 - LT-S2 VDI50 ER25F I45HRF H120

<b>Type</b>	LT-S2 Tool holder double straight
<b>Mounting</b>	VDI 50
<b>Tool output</b>	Collet nut ER 25 F - internal nut
<b>Coolant</b>	HP Internal coolant
<b>Direction of rotation</b>	r1 ↻ r2 ↻ r3 ↻
<b>Max speed [rpm]</b>	6000
<b>Max torque [Nm]</b>	60
<b>Ratio</b>	1:1
<b>H [mm]</b>	120
<b>Max pressure [bar]</b>	80
<b>Accessories</b>	N.A.
<b>Notes</b>	N.A.
<b>Mounting tips</b>	Not suitable for every application, please check

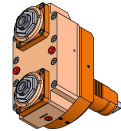

**ATTENZIONE: VERIFICARE L'ORIENTAMENTO DELLA DENTATURA VDI**

Always check live tool dimensions on the turret

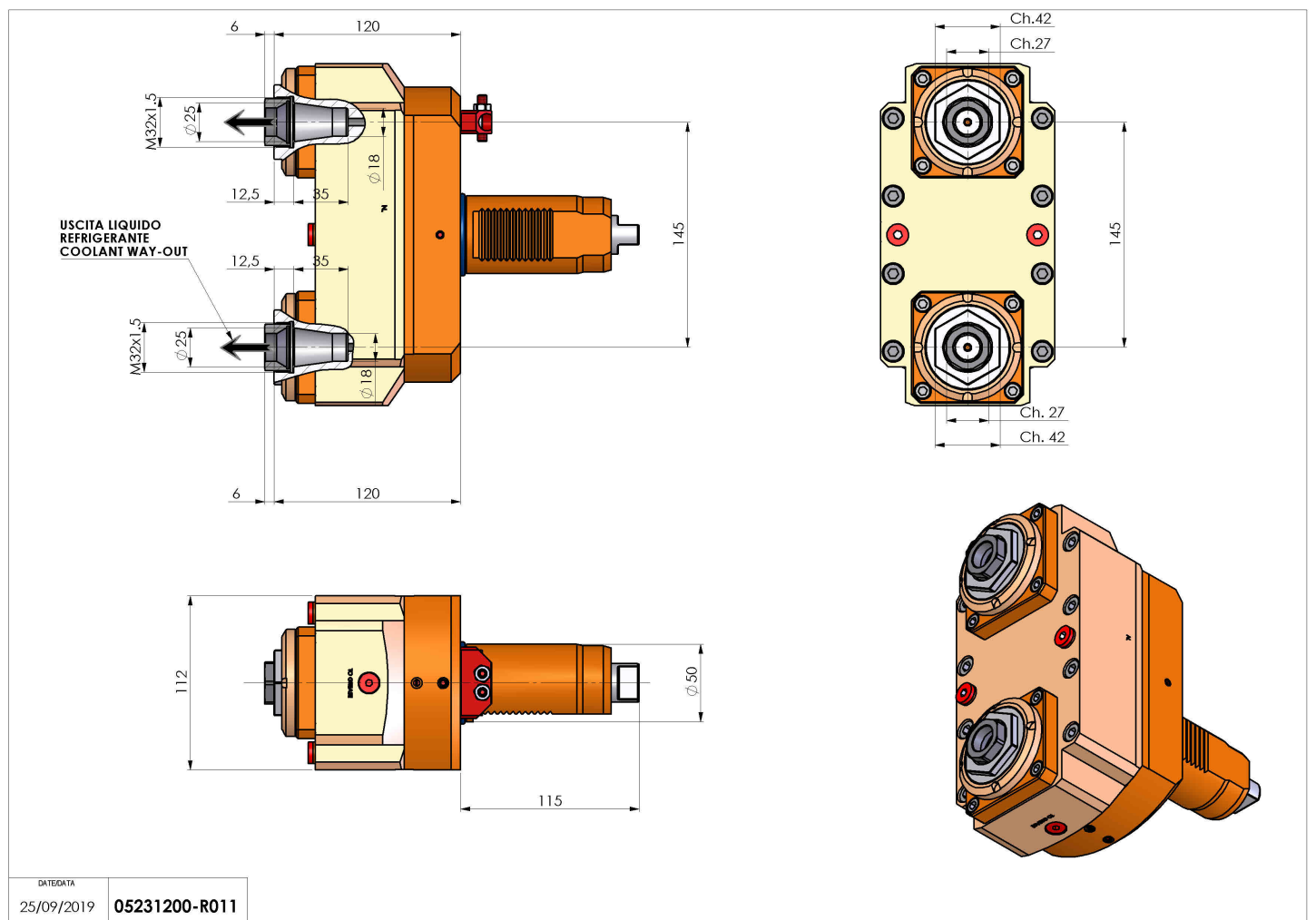

Subject to technical changes