

05229100 - LT-A VDI30 ER25 RF 1:2 H100 5480

Type	LT-A Tool holder angle 90°
Mounting	VDI 30
Tool output	Collet nut ER 25
Coolant	Internal coolant
Direction of rotation	r1 ↻ r2 ↻
Max speed [rpm]	6000
Max torque [Nm]	60
Ratio	1:2
H [mm]	100
H1 [mm]	32.5
Accessories	N.A.
Notes	N.A.

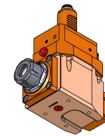

Mounting tips Not suitable for every application, please check

ATTENZIONE: VERIFICARE L'ORIENTAMENTO DELLA DENTATURA VDI

Always check live tool dimensions on the turret

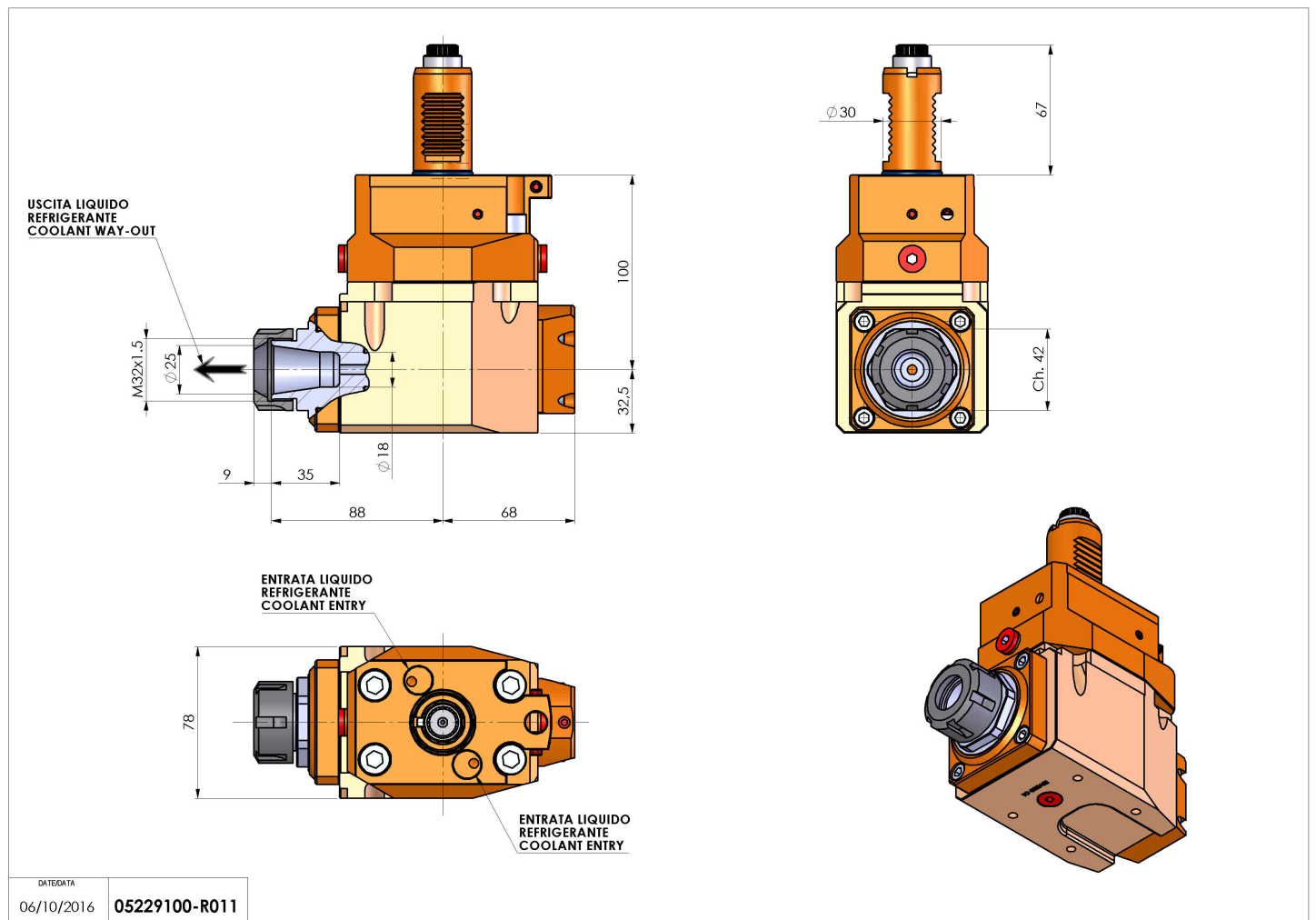

Subject to technical changes