

## 05227900 - LT-A2 VDI40 W-16 1:1 5480SA

<b>Type</b>	LT-A2 H Tool holder angle 90° double horizontal
<b>Mounting</b>	VDI 40
<b>Tool output</b>	Weldon 16 DIN1835B
<b>Coolant</b>	External coolant
<b>Direction of rotation</b>	r1  r2
<b>Max speed [rpm]</b>	3000
<b>Ratio</b>	1:1
<b>H [mm]</b>	63,5-103,5
<b>H1 [mm]</b>	27
<b>Accessories</b>	N.A.
<b>Notes</b>	N.A.
<b>Mounting tips</b>	Not suitable for every application, please check

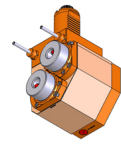

**ATTENZIONE: VERIFICARE L'ORIENTAMENTO DELLA DENTATURA VDI**

Always check live tool dimensions on the turret

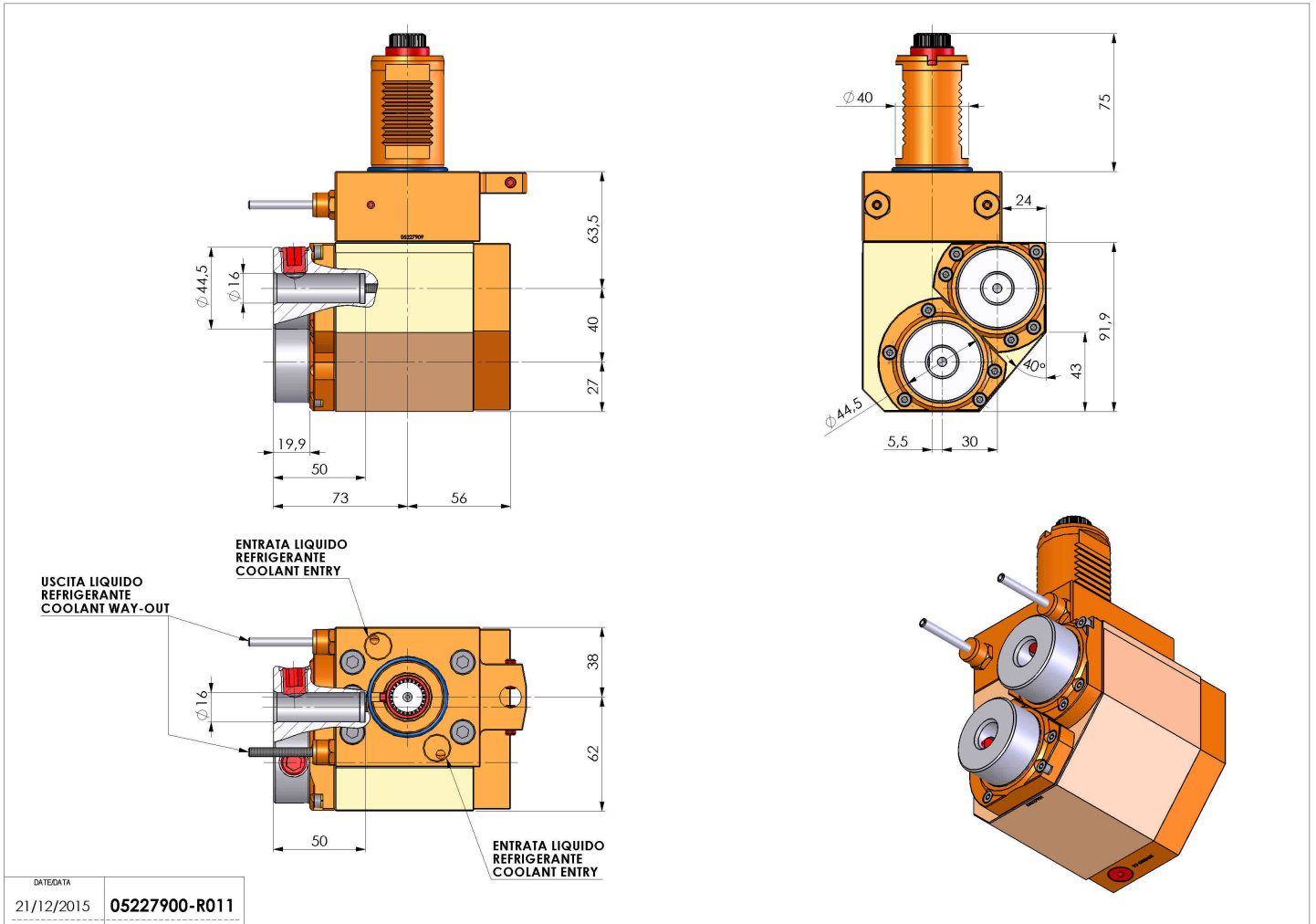

DATE/DATE: 21/12/2015 **05227900-R011**

Subject to technical changes