

05225400 - LT-S2OFS80VDI50HSK40 H118 5480

Type	LT-S2 OFS Tool holder double straight offset
Mounting	VDI 50
Tool output	Quick Change HSK40
Coolant	External coolant
Direction of rotation	r1 ↻ r2 ↻ r3 ↻
Max speed [rpm]	in r1=6000 / out r2=6000 r3=2000
Max torque [Nm]	in r1=60 / out r2=60 r3=120
Ratio	1:1 / 3:1
H [mm]	118
Accessories	N.A.
Notes	N.A.
Mounting tips	Not suitable for every application, please check

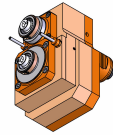

ATTENZIONE: VERIFICARE L'ORIENTAMENTO DELLA DENTATURA VDI

Always check live tool dimensions on the turret

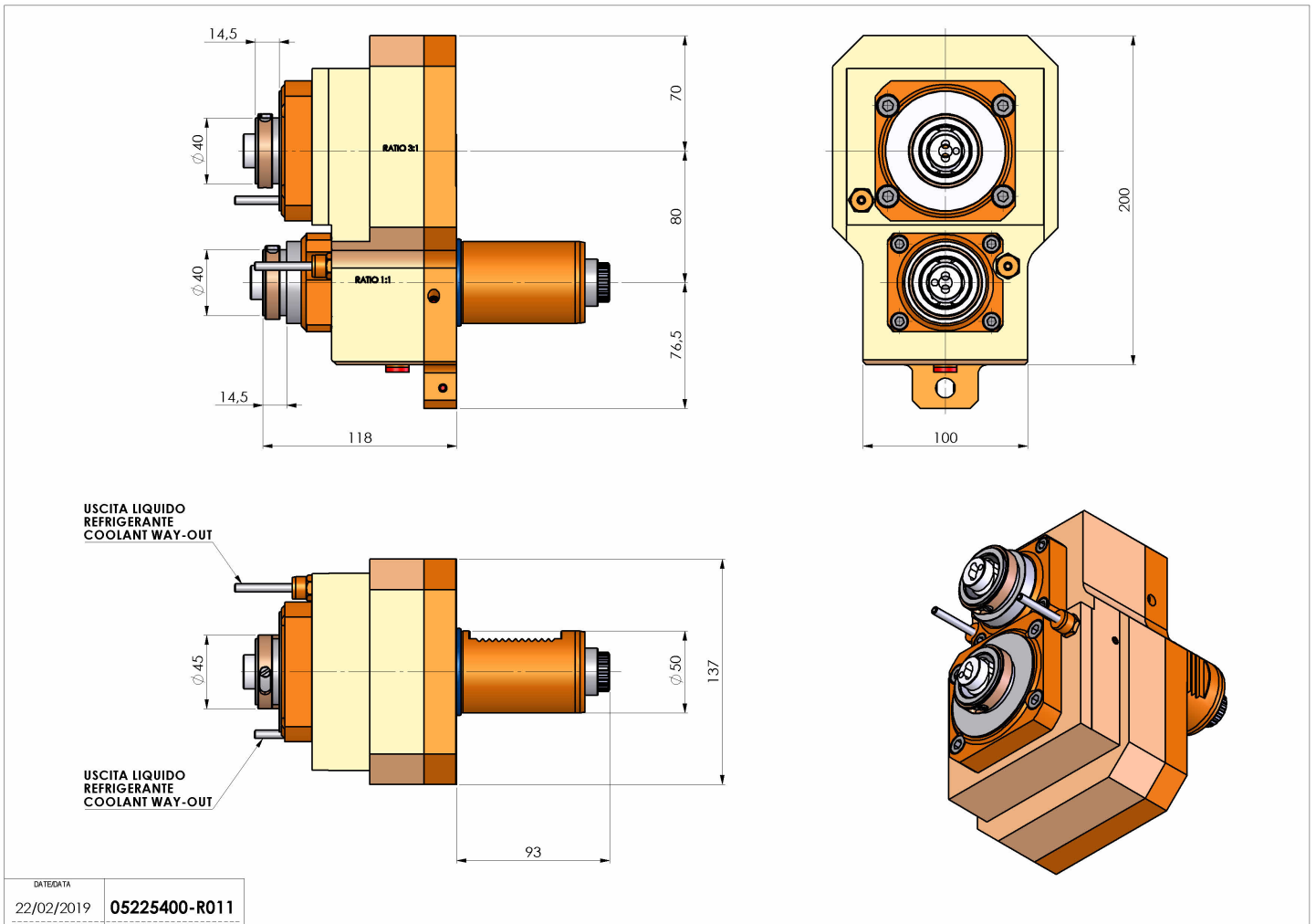

Subject to technical changes

DATE/DATE	05225400-R011
22/02/2019	