

# 05195900 - LT-S2R VDI50 HSK40 H118 1809DP

<b>Type</b>	LT-S2 Tool holder double straight
<b>Mounting</b>	VDI 50
<b>Tool output</b>	Quick Change HSK40
<b>Coolant</b>	External coolant
<b>Direction of rotation</b>	r1 ↻ r2 ↻ r3 ↻
<b>Max speed [rpm]</b>	in r1=6000 / out r2=6000 r3=3000
<b>Max torque [Nm]</b>	in r1=60 / out r2=60 r3=120
<b>Ratio</b>	1:1 / 2:1
<b>H [mm]</b>	118
<b>Accessories</b>	N.A.
<b>Notes</b>	N.A.
<b>Mounting tips</b>	Not suitable for every application, please check

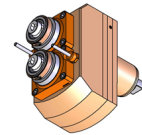

**ATTENZIONE: VERIFICARE L'ORIENTAMENTO DELLA DENTATURA VDI**

Always check live tool dimensions on the turret

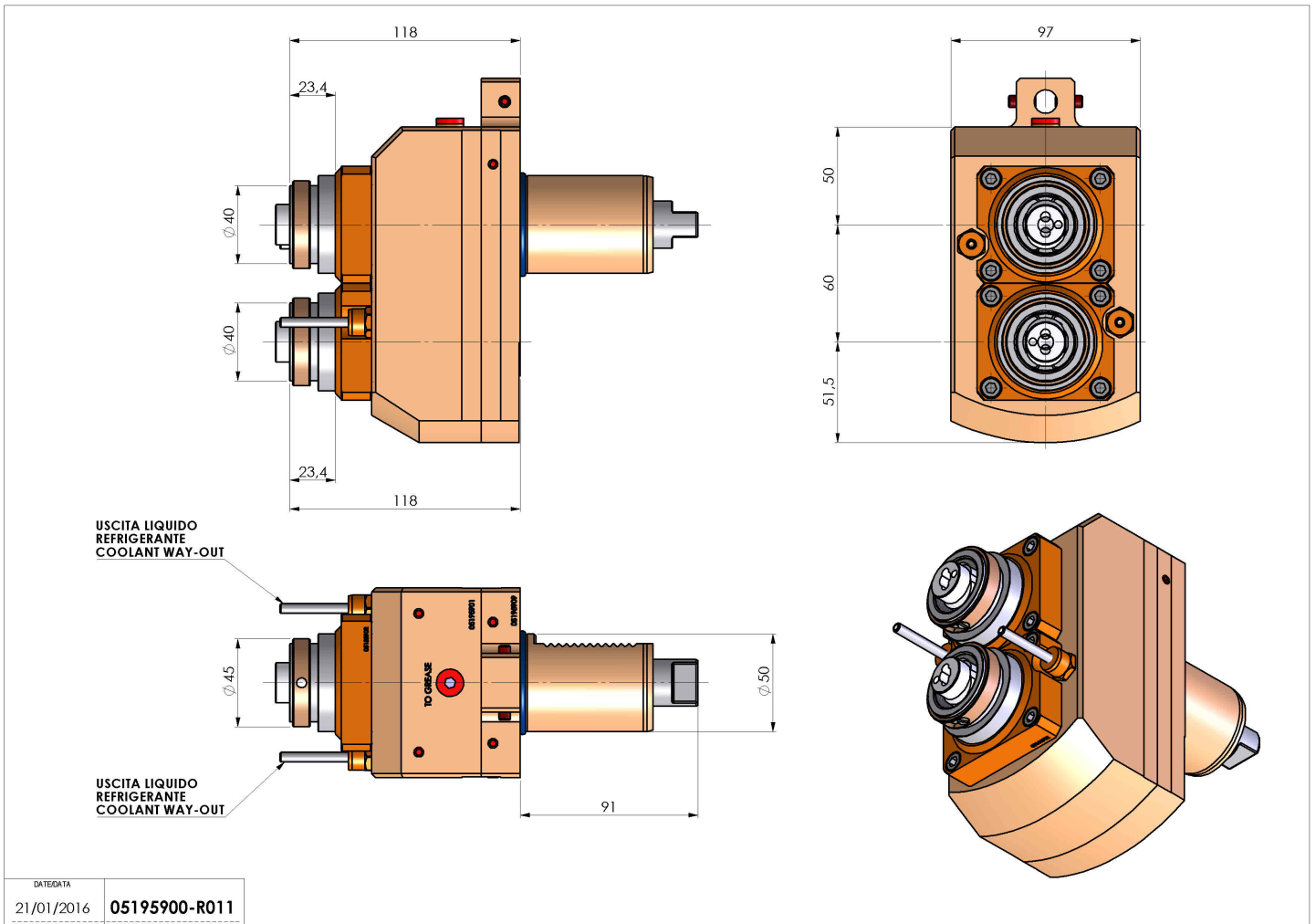

DATE/DATE	05195900-R011
21/01/2016	

Subject to technical changes