

05183500 - LT-A VDI30 DIN138-16LRH85 5482

Type	LT-A Tool holder angle 90°
Mounting	VDI 30
Tool output	Shell-Mill DIN138 16
Coolant	External coolant
Direction of rotation	r1 r2
Max speed [rpm]	6000
Max torque [Nm]	30
Ratio	1:1
H [mm]	85
H1 [mm]	32,5
Accessories	N.A.
Notes	N.A.

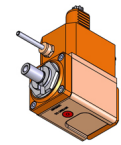

Mounting tips Not suitable for every application, please check

ATTENZIONE: VERIFICARE L'ORIENTAMENTO DELLA DENTATURA VDI

Always check live tool dimensions on the turret

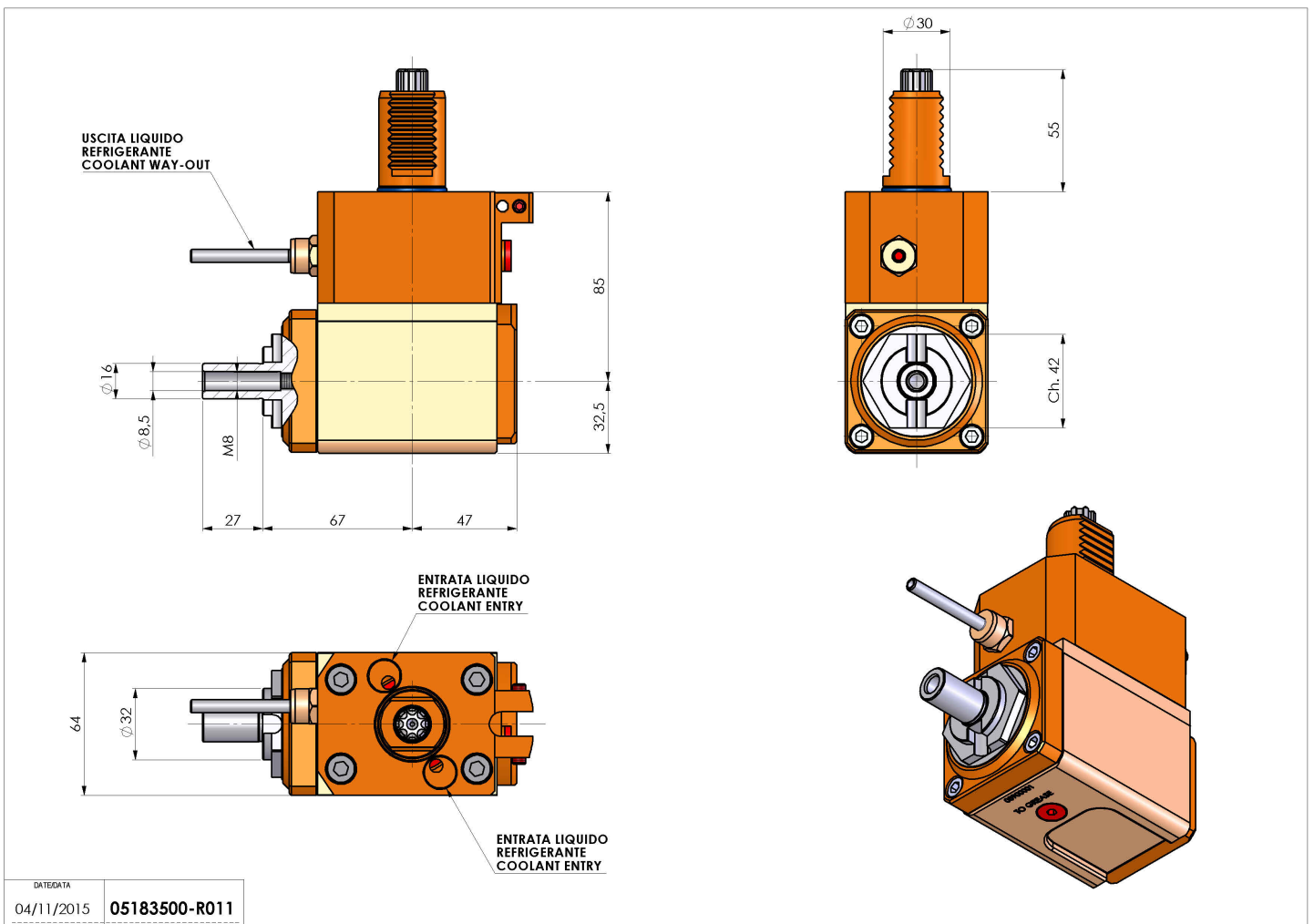

DATE/DATE: 04/11/2015 **05183500-R011**

Subject to technical changes