

05180300 - LT-S VDI40 ER32 RFH99 DIN5482

Type	LT-S Tool holder straight
Mounting	VDI 40
Tool output	Collet nut ER 32
Coolant	Internal coolant
Direction of rotation	r1 r2
Max speed [rpm]	6000
Max torque [Nm]	63
Ratio	1:1
H [mm]	99
Accessories	
Notes	N.A.
Mounting tips	Not suitable for every application, please check

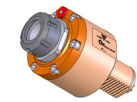

ATTENZIONE: VERIFICARE L'ORIENTAMENTO DELLA DENTATURA VDI

Always check live tool dimensions on the turret

USCITA LIQUIDO REFRIGERANTE COOLANT WAY-OUT

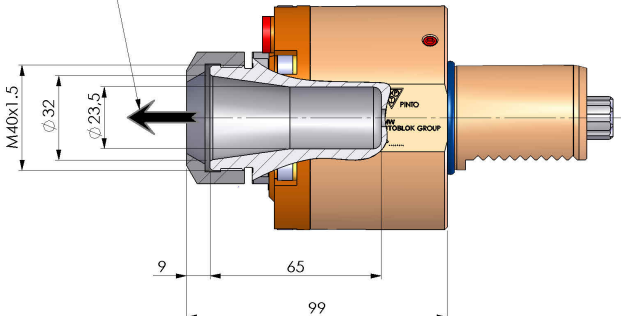

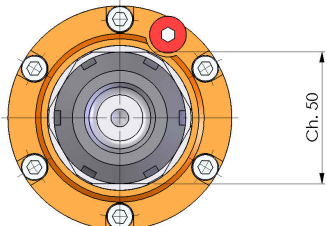

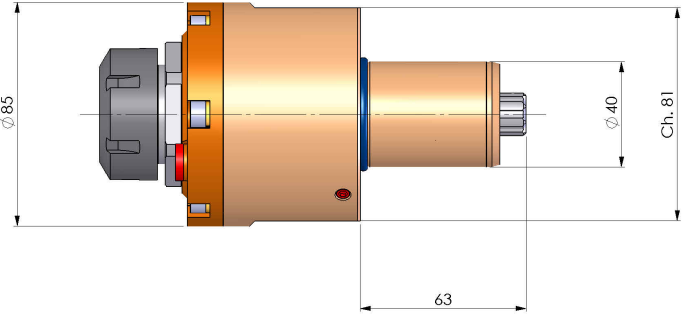

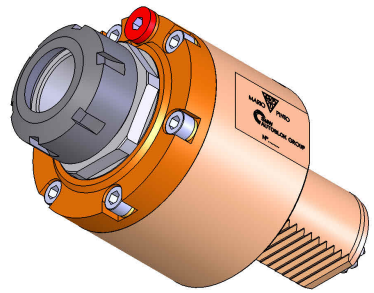

DATE/DATE

03/11/2015

05180300-R011

Subject to technical changes