



## 05173000 - LT-S VDI30 ER25-F H62 BA

<b>Type</b>	LT-S Tool holder straight
<b>Mounting</b>	VDI 30
<b>Tool output</b>	Collet nut ER 25 F - internal nut
<b>Coolant</b>	External coolant
<b>Direction of rotation</b>	r1  r2 
<b>Max speed [rpm]</b>	6000
<b>Max torque [Nm]</b>	30
<b>Ratio</b>	1:1
<b>H [mm]</b>	62.5
<b>Accessories</b>	
<b>Notes</b>	Cannot be mounted near an offset angular
<b>Mounting tips</b>	Not suitable for every application, please check

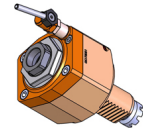

**ATTENZIONE: VERIFICARE L'ORIENTAMENTO DELLA DENTATURA VDI**

Always check live tool dimensions on the turret

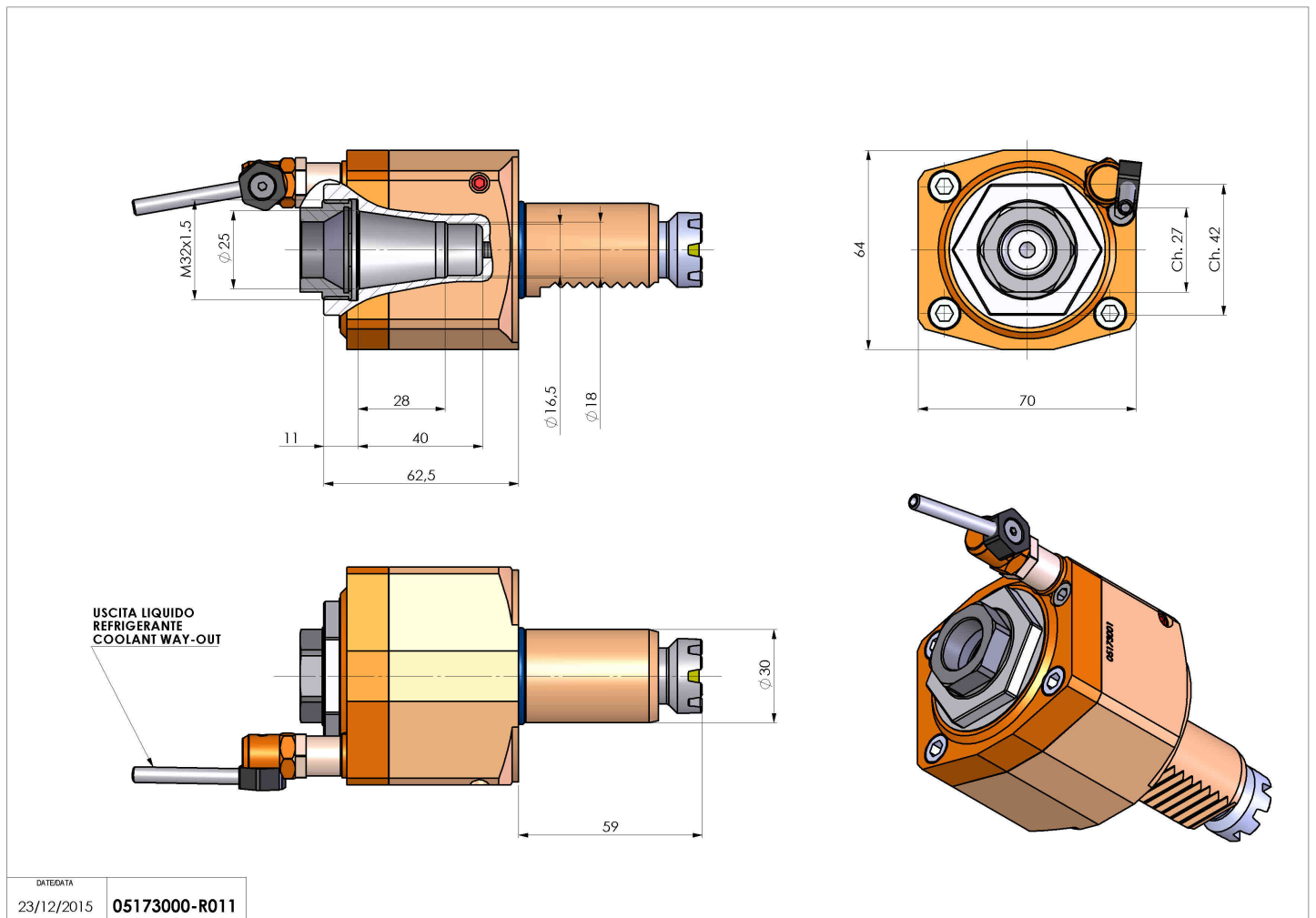

DATE/DATE  
23/12/2015 05173000-R011

Subject to technical changes