

# 05171000 - LT-A VDI40 ER32F 2:1 H90 BA

Type	LT-A Tool holder angle 90°
Mounting	VDI 40
Tool output	Collet nut ER 32 F - internal nut
Coolant	External coolant
Direction of rotation	r1 ↻ r2 ↻
Max speed [rpm]	in 6000 / out 3000
Max torque [Nm]	in 60 / out 120
Ratio	2:1
H [mm]	90
H1 [mm]	38
Accessories	N.A.
Notes	N.A.
Mounting tips	Not suitable for every application, please check

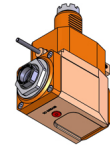

**ATTENZIONE: VERIFICARE L'ORIENTAMENTO DELLA DENTATURA VDI**

Always check live tool dimensions on the turret

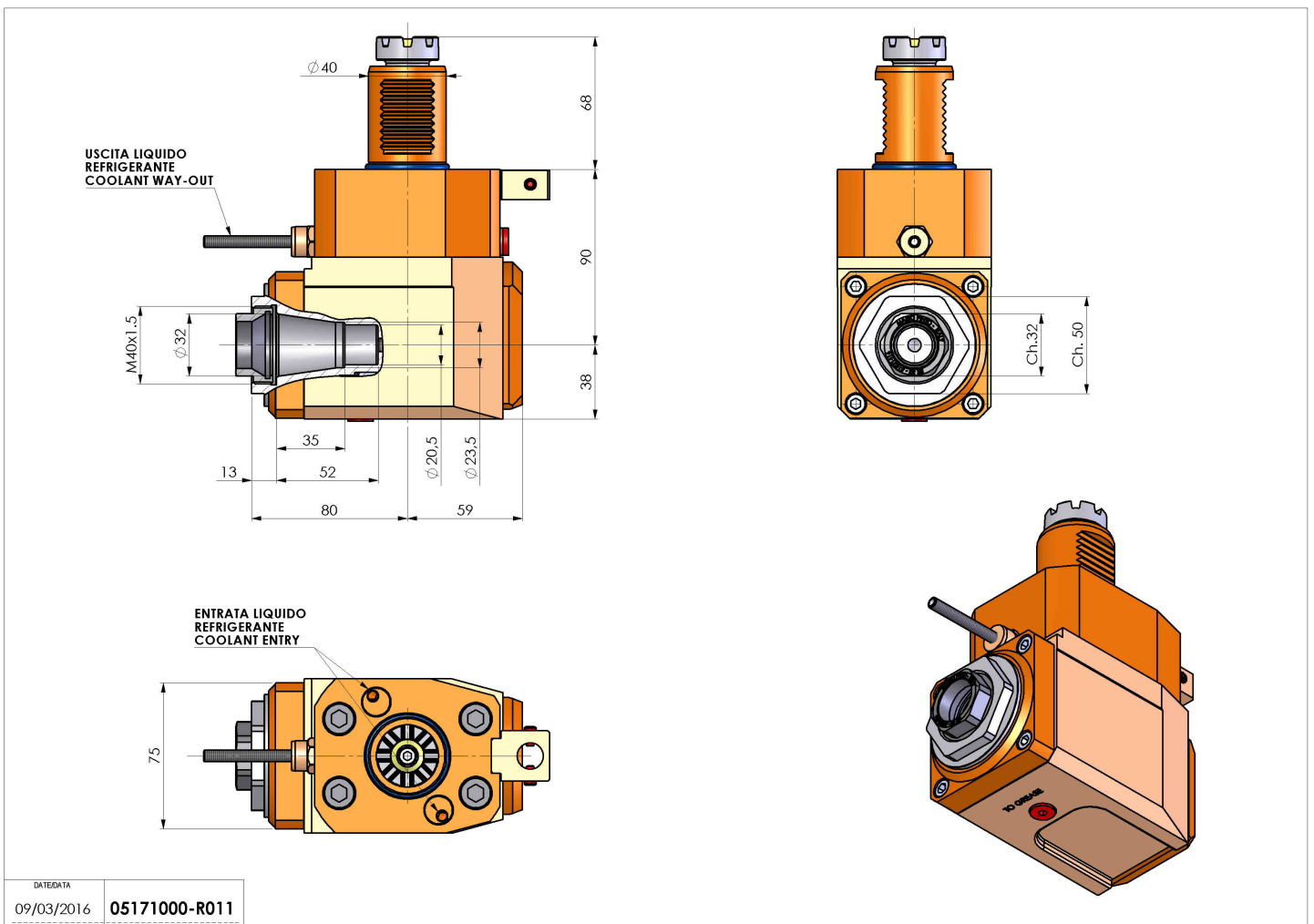

DATE/ATA	09/03/2016	05171000-R011
----------	------------	---------------

Subject to technical changes