

# 05169800 - LT-A66 D40 ER20F LR1:2HRF H118

<b>Type</b>	LT-A(a) Tool holder with fix angle (alpha)
<b>Mounting</b>	CYLINDRICAL SHANK 40
<b>Tool output</b>	Collet nut ER 20 F - internal nut
<b>Coolant</b>	HP Internal coolant
<b>Direction of rotation</b>	r1 ↻ r2 ↻
<b>Max speed [rpm]</b>	in 4500 / out 9000
<b>Max torque [Nm]</b>	in 50 / out 25
<b>Ratio</b>	1:2
<b>H [mm]</b>	118
<b>H1 [mm]</b>	127.5
<b>Max pressure [bar]</b>	80
<b>Accessories</b>	N.A.
<b>Notes</b>	N.A.
<b>Mounting tips</b>	Not suitable for every application, please check

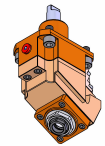

Always check live tool dimensions on the turret

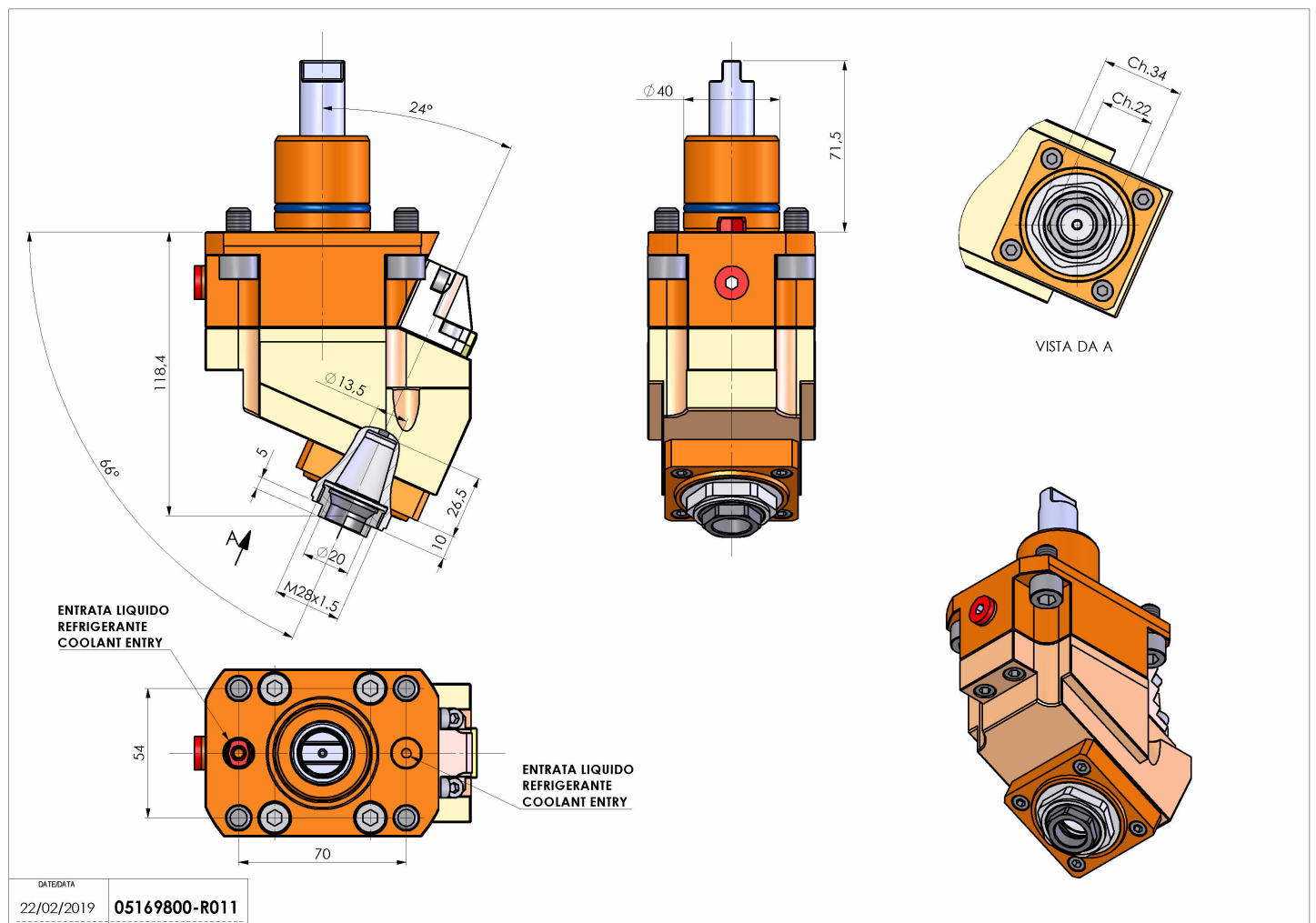

Subject to technical changes