

05167400 - LT-S D44 C32 H49

Type	LT-S Tool holder straight
Mounting	CYLINDRICAL SHANK 44
Tool output	Polygonal shank C32 ISO 26623-1
Coolant	External coolant
Direction of rotation	r1 r2
Max speed [rpm]	6000
Max torque [Nm]	40
Ratio	1:1
H [mm]	49
Accessories	N.A.
Notes	N.A.
Mounting tips	Not suitable for every application, please check

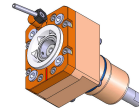

Always check live tool dimensions on the turret

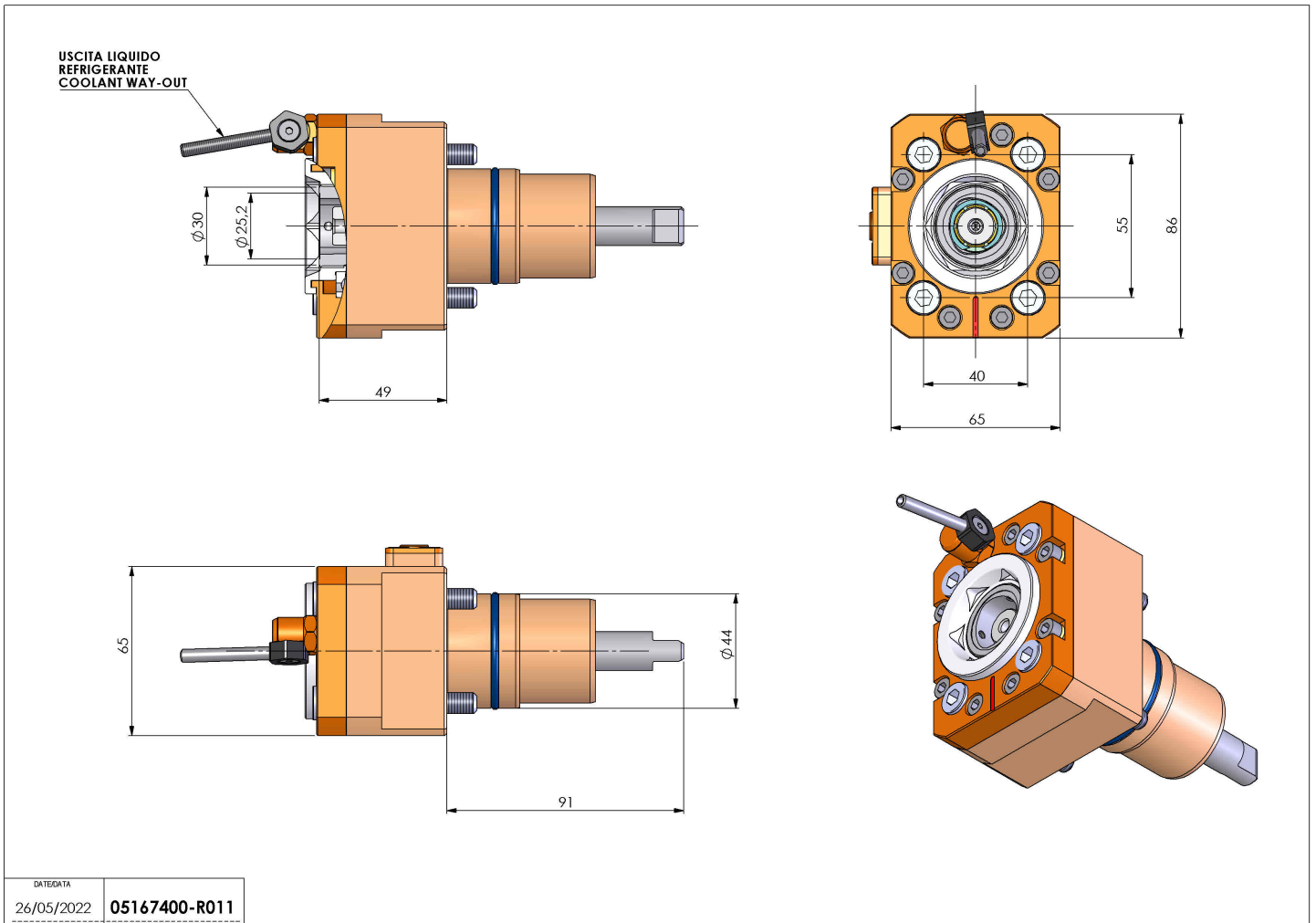

DATE/DATE	26/05/2022
PART NUMBER	05167400-R011

Subject to technical changes