



## 05167300 - LT-A D44 C32 LR H60

<b>Type</b>	LT-A Tool holder angle 90°
<b>Mounting</b>	CYLINDRICAL SHANK 44
<b>Tool output</b>	Polygonal shank C32 ISO 26623-1
<b>Coolant</b>	External coolant
<b>Direction of rotation</b>	r1  r2 
<b>Max speed [rpm]</b>	6000
<b>Max torque [Nm]</b>	40
<b>Ratio</b>	1:1
<b>H [mm]</b>	60
<b>H1 [mm]</b>	32.5
<b>Accessories</b>	N.A.
<b>Notes</b>	N.A.
<b>Mounting tips</b>	Not suitable for every application, please check



Always check live tool dimensions on the turret

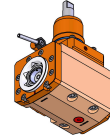
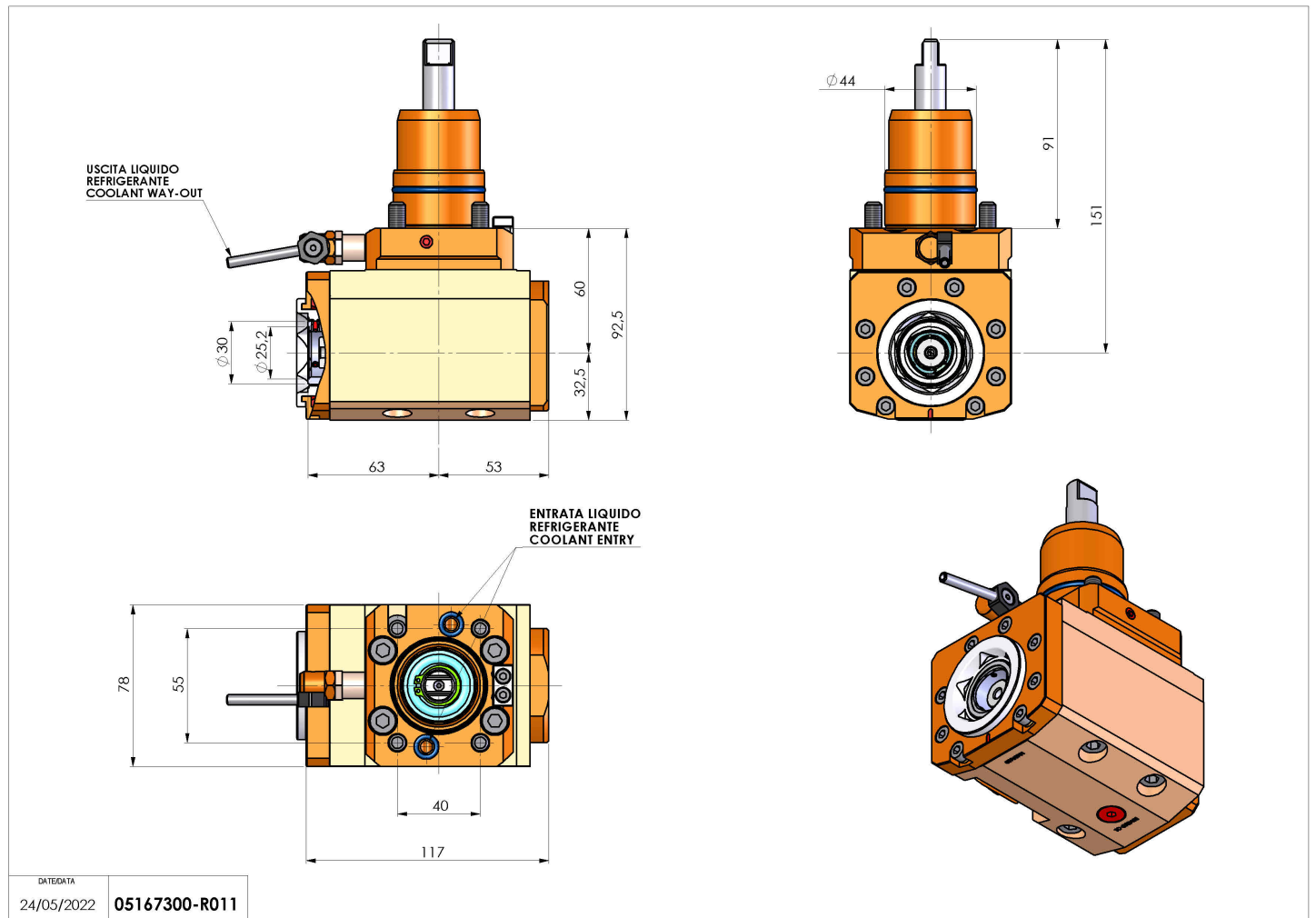

DATE/DATE  
24/05/2022 05167300-R011

Subject to technical changes