

05166100 - LT-S D44 ER25F OFS49.5 HRF H65

Type	LT-S OFS Tool holder straight offset
Mounting	CYLINDRICAL SHANK 44
Tool output	Collet nut ER 25 F - internal nut
Coolant	HP Internal coolant
Direction of rotation	r1 r2
Max speed [rpm]	6000
Max torque [Nm]	30
Ratio	1:1
H [mm]	65
Max pressure [bar]	80
Accessories	N.A.
Notes	N.A.
Mounting tips	Not suitable for every application, please check

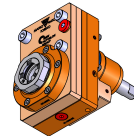

Always check live tool dimensions on the turret

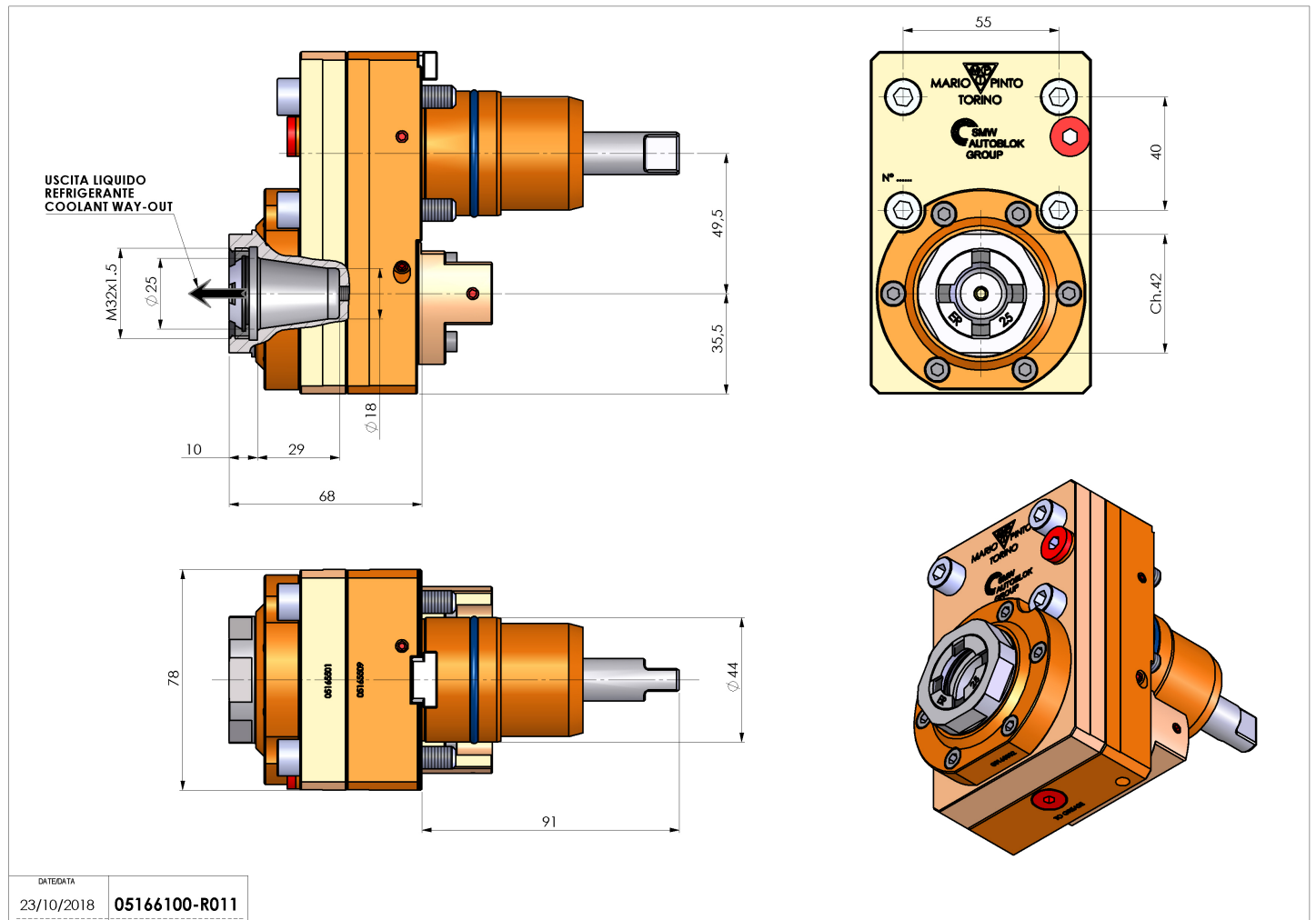

DATE/DATE	05166100-R011
23/10/2018	

Subject to technical changes