



05165600 - LT-A D44 ER20F L-R HRF 1:2 H60

| | |
|------------------------------|---|
| Type | LT-A Tool holder angle 90° |
| Mounting | CYLINDRICAL SHANK 44 |
| Tool output | Collet nut ER 20 F - internal nut |
| Coolant | HP Internal coolant |
| Direction of rotation | r1  r2  |
| Max speed [rpm] | in 6000 / out 12000 |
| Max torque [Nm] | in 10 / out 5 |
| Ratio | 1:2 |
| H [mm] | 60 |
| H1 [mm] | 28 |
| Max pressure [bar] | 80 |
| Accessories | N.A. |
| Notes | N.A. |
| Mounting tips | Not suitable for every application, please check |



Always check live tool dimensions on the turret

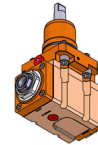
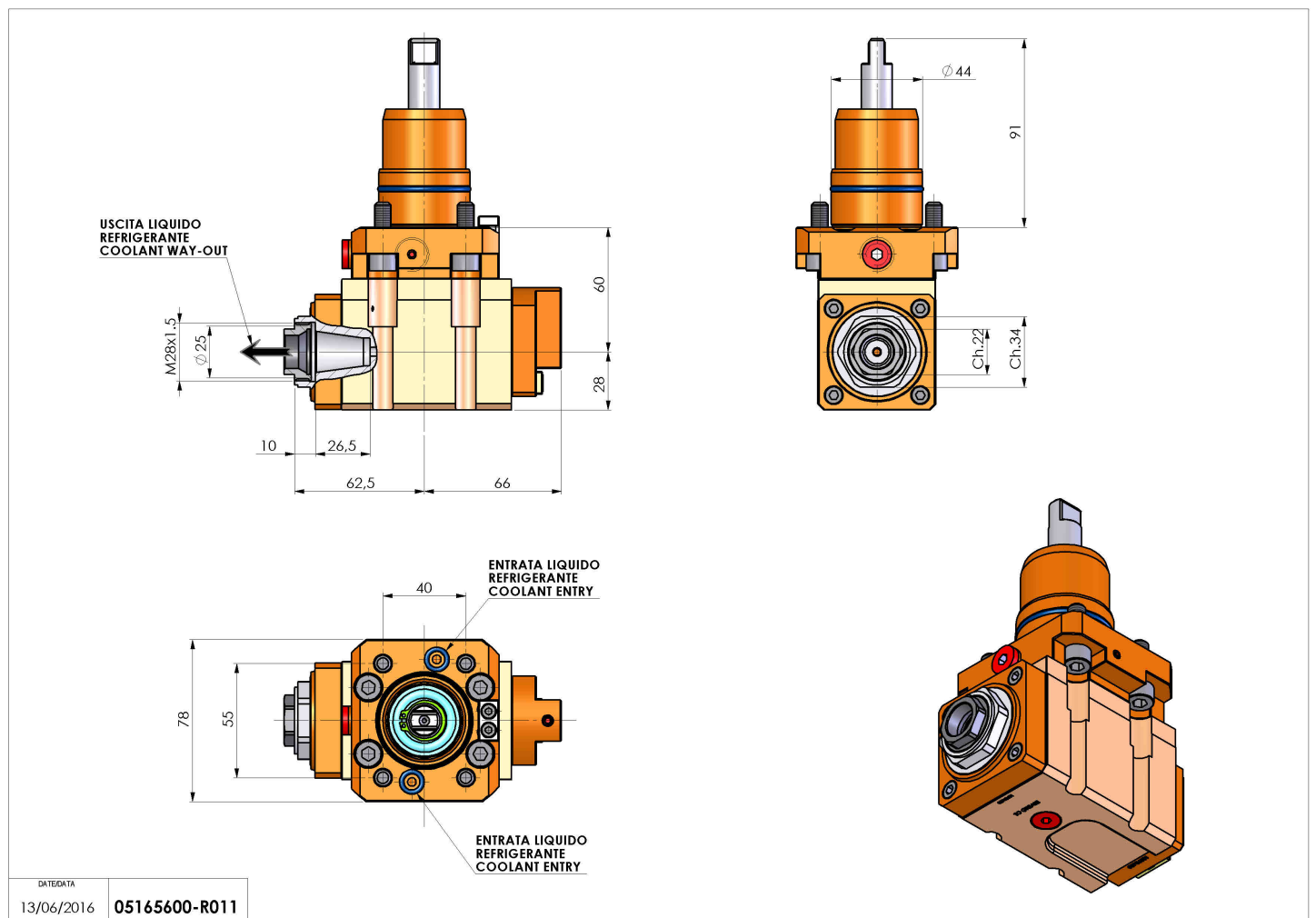

Subject to technical changes

DATE/ATA
13/06/2016 05165600-R011