

# 05164400 - LT-S D40 138-16 OF72 LR HS H91

<b>Type</b>	LT-S OFS Tool holder straight offset
<b>Mounting</b>	CYLINDRICAL SHANK 40
<b>Tool output</b>	Shell-Mill DIN138 16
<b>Coolant</b>	External coolant
<b>Offset [mm]</b>	72
<b>Direction of rotation</b>	r1  r2
<b>Max speed [rpm]</b>	10000
<b>Max torque [Nm]</b>	50
<b>Ratio</b>	1:1
<b>H [mm]</b>	91
<b>Accessories</b>	N.A.
<b>Notes</b>	N.A.
<b>Mounting tips</b>	Not suitable for every application, please check

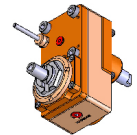

Always check live tool dimensions on the turret

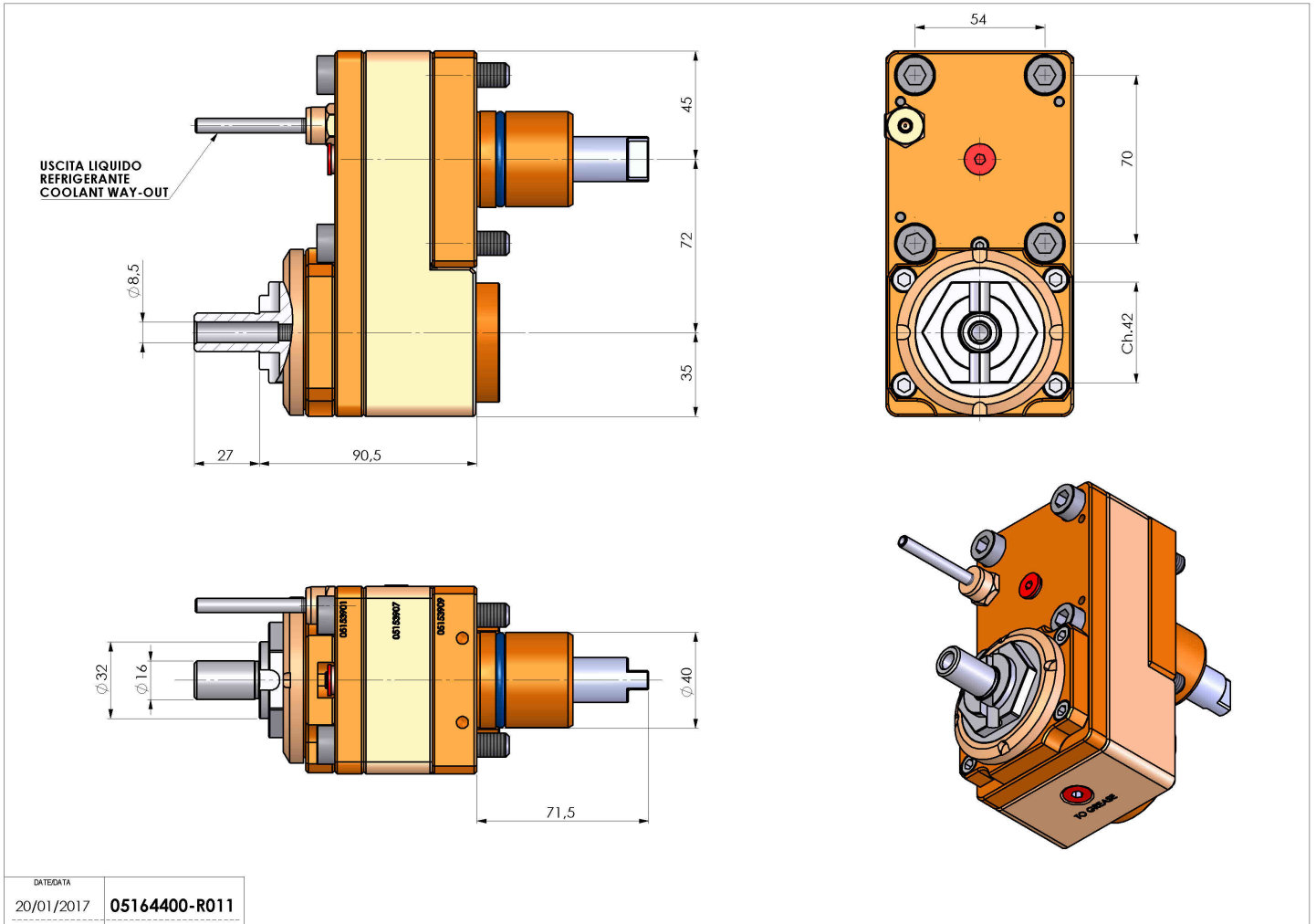

DATE/DATE	05164400-R011
20/01/2017	

Subject to technical changes