



05164200 - LT-S D40 ER25OF72LR HRF H108MU

Type	LT-S OFS Tool holder straight offset
Mounting	CYLINDRICAL SHANK 40
Tool output	Collet nut ER 25
Coolant	HP Internal coolant
Offset [mm]	72
Direction of rotation	r1  r2 
Max speed [rpm]	6000
Max torque [Nm]	50
Ratio	1:1
H [mm]	108.5
Max pressure [bar]	80
Accessories	
Notes	N.A.
Mounting tips	Not suitable for every application, please check



Always check live tool dimensions on the turret

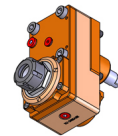
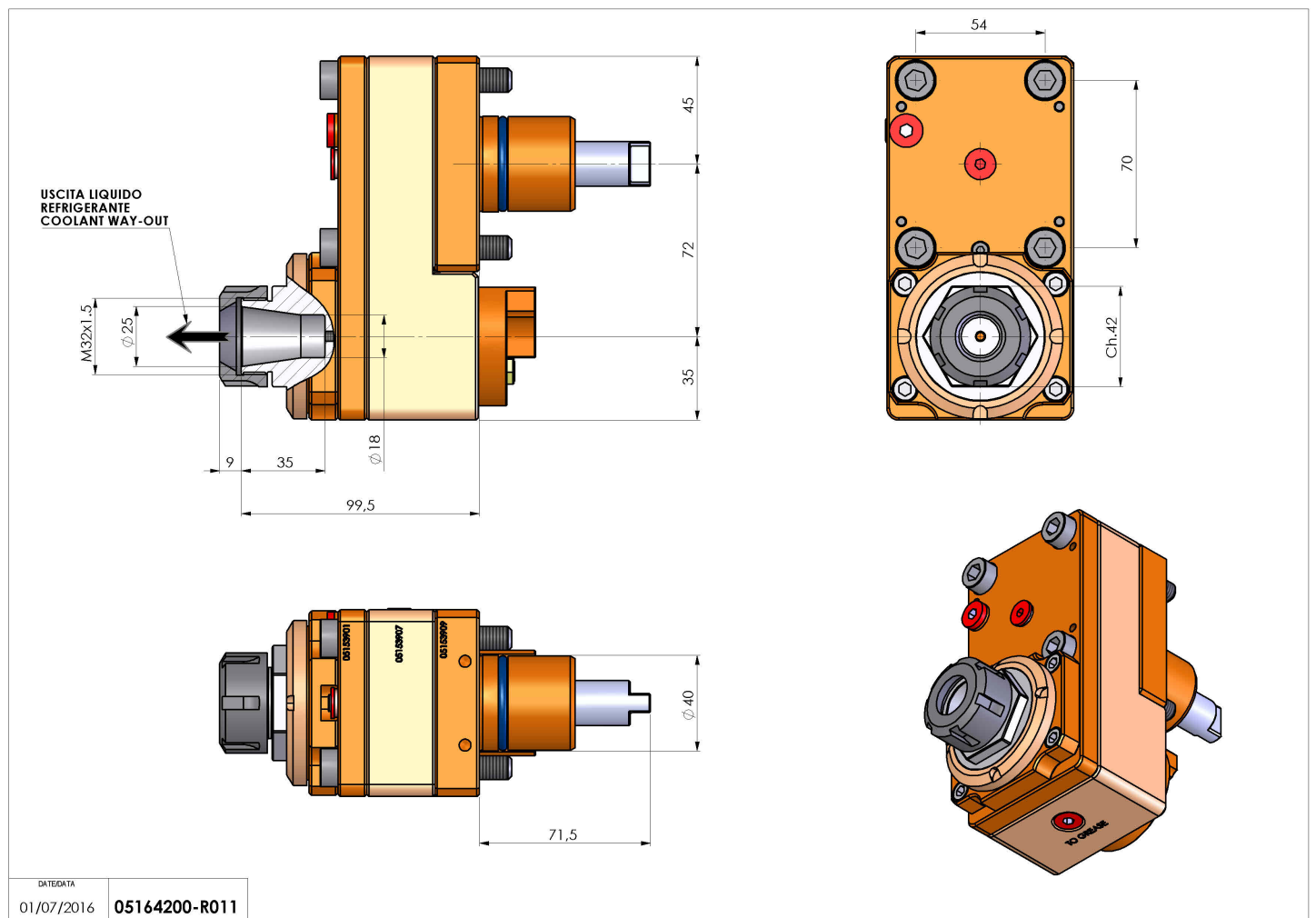

Subject to technical changes