

05163600 - LT-A D40ER25F LR RF-HPR H100MU

Type	LT-A Tool holder angle 90°
Mounting	CYLINDRICAL SHANK 40
Tool output	Collet nut ER 25 F - internal nut
Coolant	HP Internal coolant
Direction of rotation	r1 r2
Max speed [rpm]	6000
Max torque [Nm]	40
Ratio	1:1
H [mm]	100
H1 [mm]	32,5
Max pressure [bar]	80
Accessories	N.A.
Notes	N.A.
Mounting tips	Not suitable for every application, please check

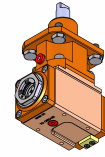

Always check live tool dimensions on the turret

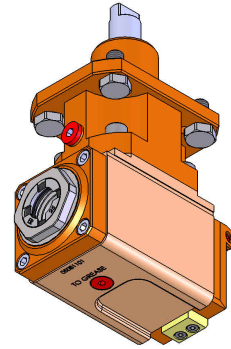
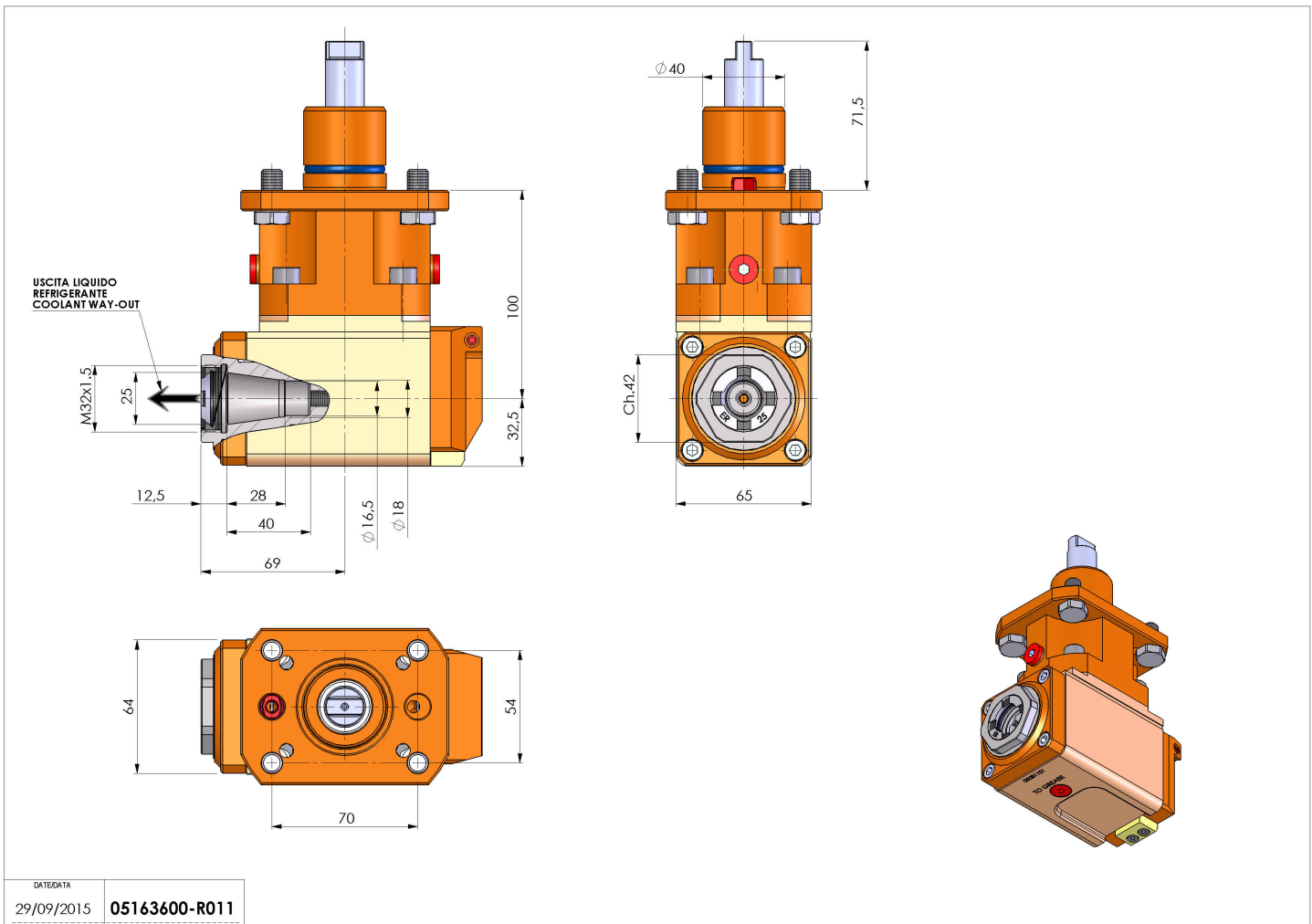

DATE/DATE
29/09/2015 05163600-R011

Subject to technical changes