



05163300 - LT-A D40 ER32F RF L-R H100 MU

Type	LT-A Tool holder angle 90°
Mounting	CYLINDRICAL SHANK 40
Tool output	Collet nut ER 32 F - internal nut
Coolant	Internal coolant
Direction of rotation	r1  r2 
Max speed [rpm]	6000
Max torque [Nm]	63
Ratio	1:1
H [mm]	100
H1 [mm]	36
Accessories	N.A.
Notes	N.A.
Mounting tips	Not suitable for every application, please check



Always check live tool dimensions on the turret

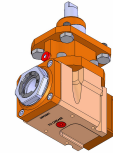
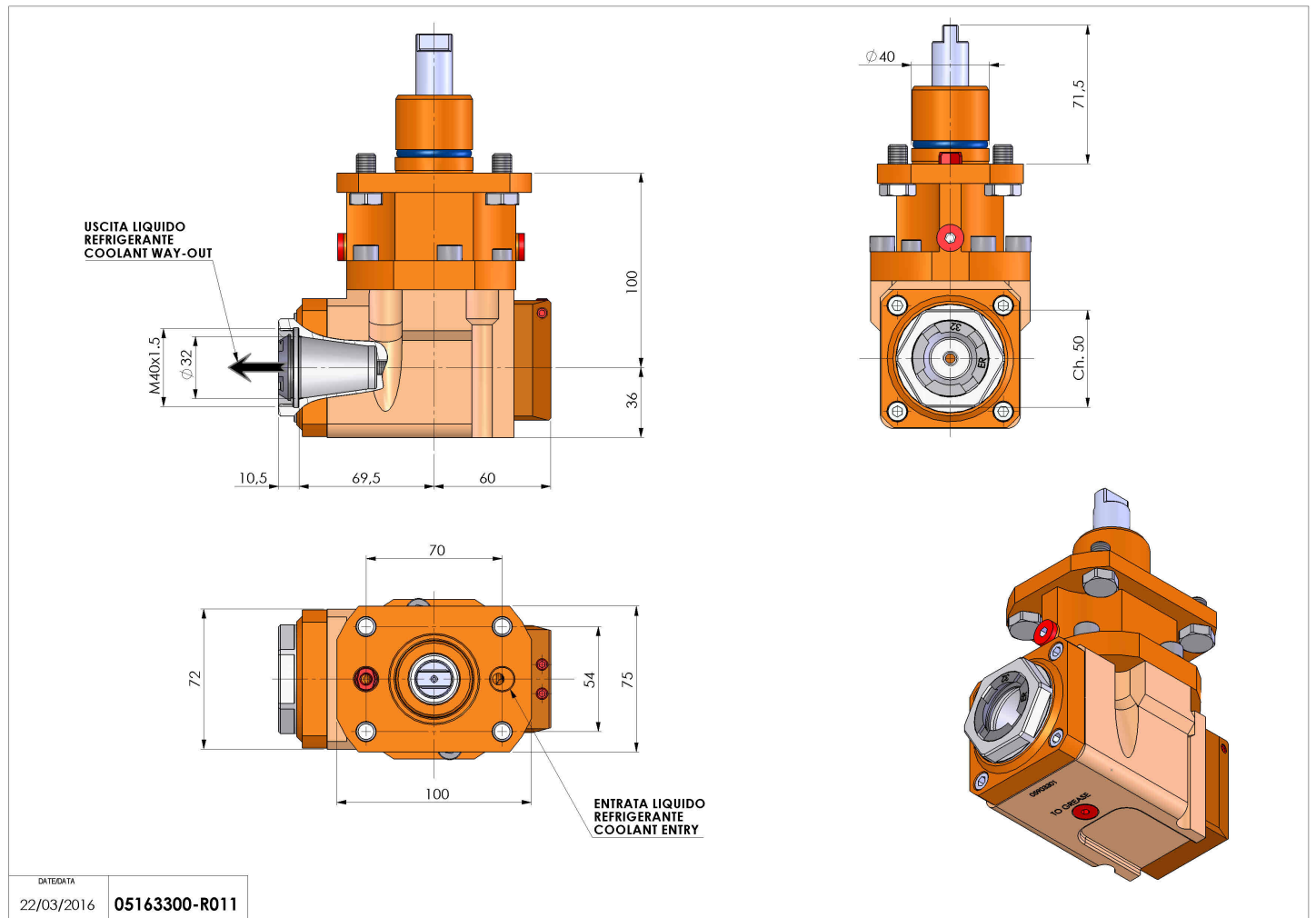

Subject to technical changes

DATE/DATE
22/03/2016 05163300-R011