

05162100 - LT-A D40 C40 OFS-30 HRF H95

Type	LT-A OFS Tool holder offset angle 90°
Mounting	CYLINDRICAL SHANK 40
Tool output	Polygonal shank C40 ISO 26623-1
Coolant	HP Internal coolant
Offset [mm]	30
Direction of rotation	r1 ↻ r2 ↻
Max speed [rpm]	6000
Max torque [Nm]	50
Ratio	1:1
H [mm]	95
H1 [mm]	41
Max pressure [bar]	80
Accessories	N.A.
Notes	N.A.
Mounting tips	Not suitable for every application, please check

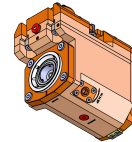

Always check live tool dimensions on the turret

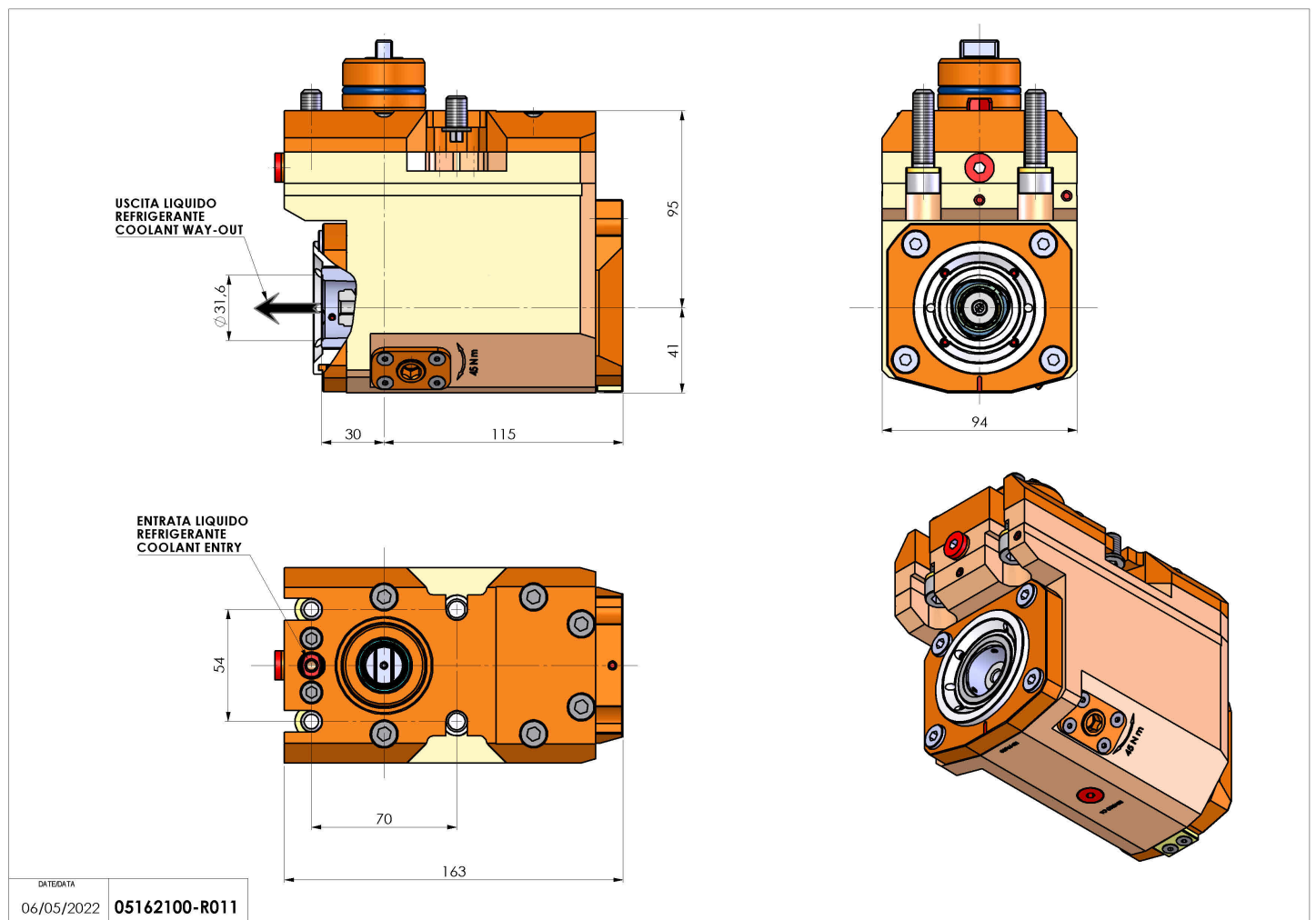

DATE/DATE
06/05/2022 05162100-R011

Subject to technical changes