

## 05160800 - LT-A D35 ER20F 1:2 H60 MU

<b>Type</b>	LT-A Tool holder angle 90°
<b>Mounting</b>	CYLINDRICAL SHANK 35
<b>Tool output</b>	Collet nut ER 20 F - internal nut
<b>Coolant</b>	External coolant
<b>Direction of rotation</b>	r1 ↻ r2 ↻
<b>Max speed [rpm]</b>	in 6000 / out 12000
<b>Max torque [Nm]</b>	in 10 / out 5
<b>Ratio</b>	1:2
<b>H [mm]</b>	60
<b>H1 [mm]</b>	28
<b>Accessories</b>	N.A.
<b>Notes</b>	N.A.
<b>Mounting tips</b>	Not suitable for every application, please check

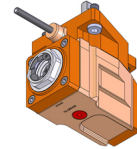

Always check live tool dimensions on the turret

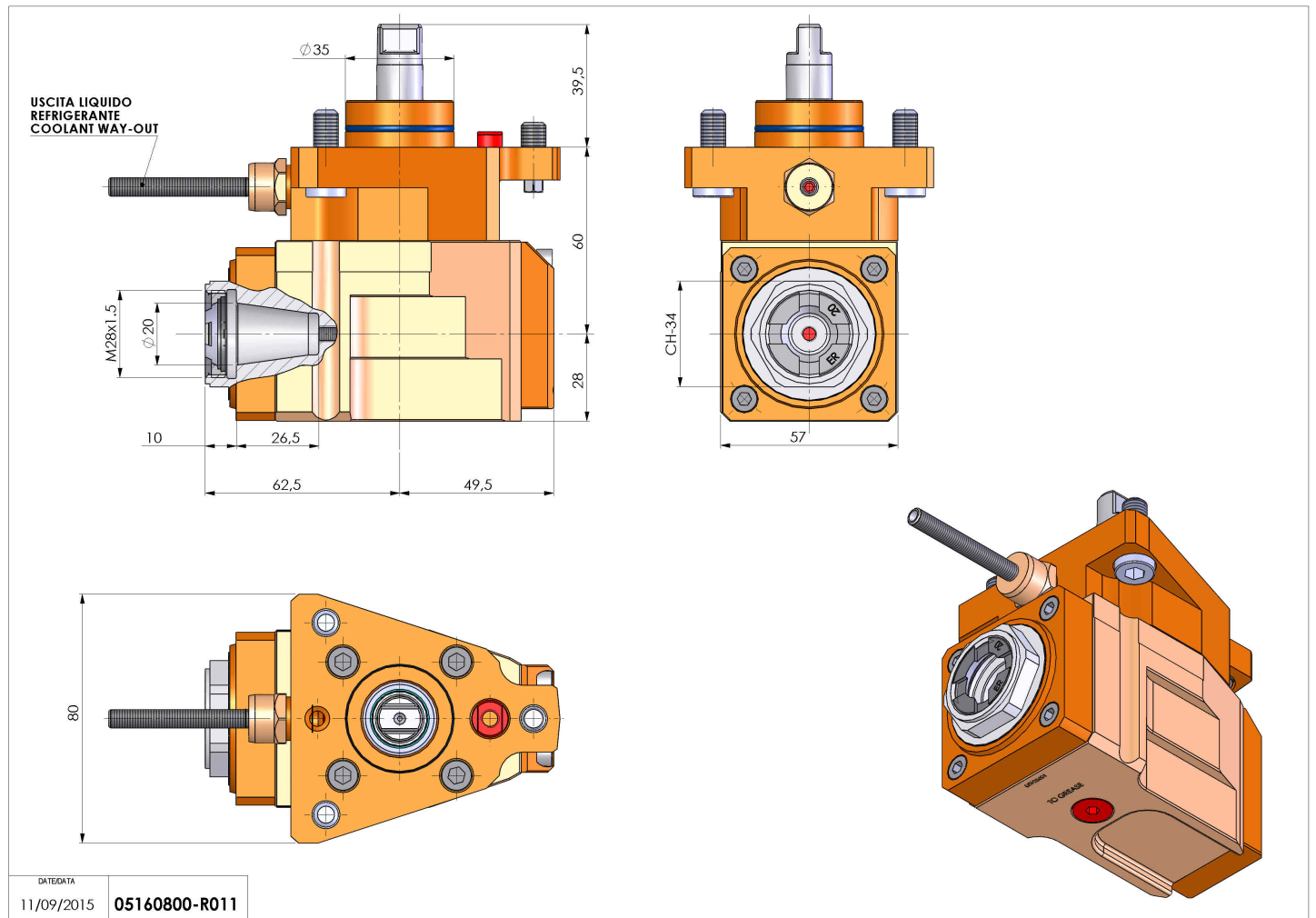

DATE/DATE  
11/09/2015 05160800-R011

Subject to technical changes