

05157200 - LT-S D55 DIN138-22OFS100H110MU

| | |
|------------------------------|--|
| Type | LT-S OFS Tool holder straight offset |
| Mounting | CYLINDRICAL SHANK 55 |
| Tool output | Shell-Mill DIN138 22 |
| Coolant | External coolant |
| Offset [mm] | 100 |
| Direction of rotation | r1 ↻ r2 ↻ |
| Max speed [rpm] | 6000 |
| Max torque [Nm] | 60 |
| Ratio | 1:1 |
| H [mm] | 110 |
| Accessories | N.A. |
| Notes | N.A. |
| Mounting tips | Not suitable for every application, please check |

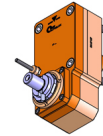

Always check live tool dimensions on the turret

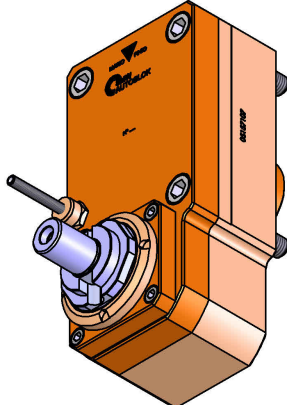
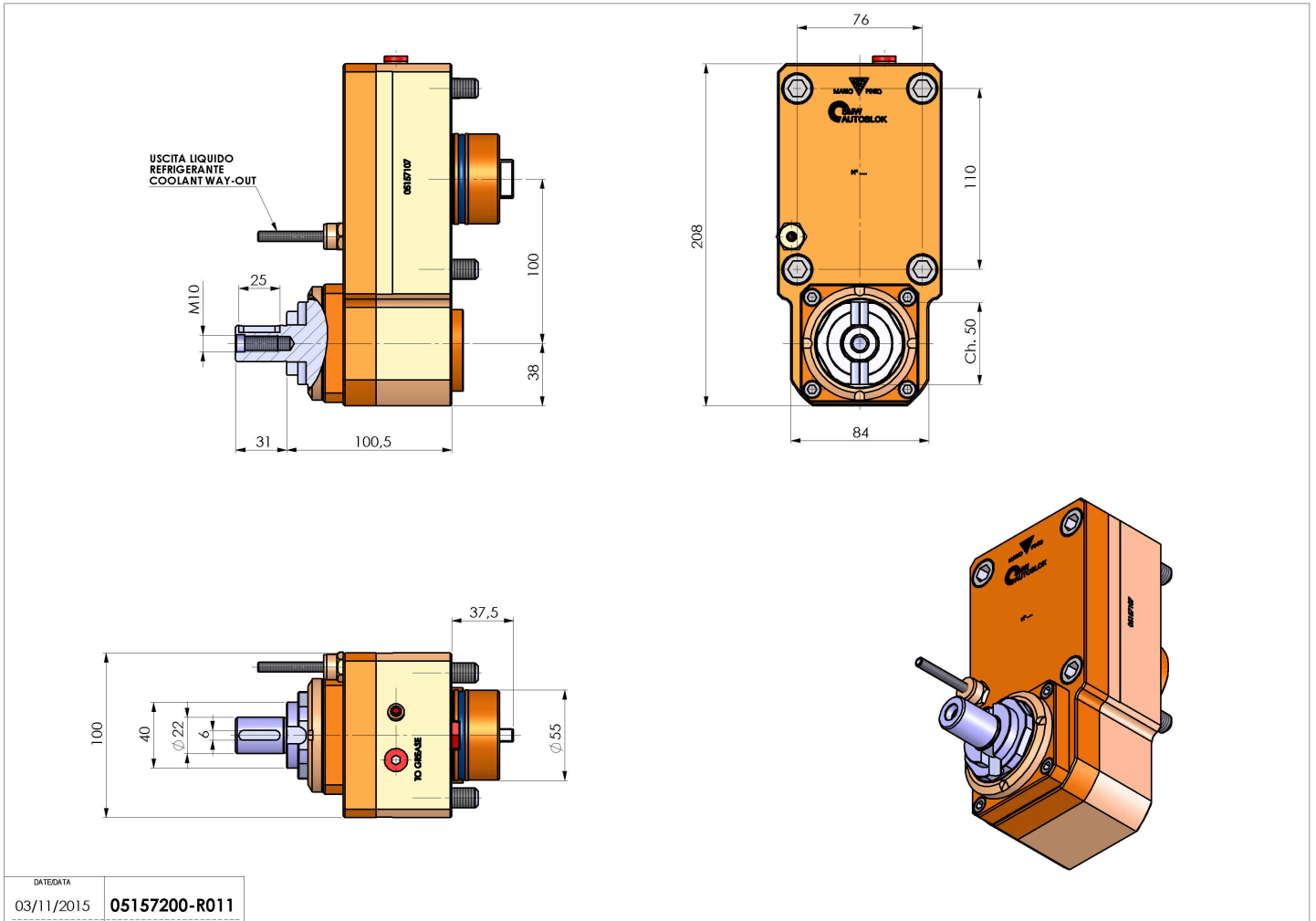

| | |
|---------------|------------|
| DATE/DATE | 03/11/2015 |
| 05157200-R011 | |

Subject to technical changes