

## 05156300 - LT-SAW D40 L 1:1 H90

<b>Type</b>	LT-HOB-SAW Hobbing/tool holder saw
<b>Mounting</b>	CYLINDRICAL SHANK 40
<b>Tool output</b>	Shank kit Ø16-Ø22-Ø27
<b>Coolant</b>	External coolant
<b>Max speed [rpm]</b>	6000
<b>Max torque [Nm]</b>	60
<b>Ratio</b>	1:1
<b>H [mm]</b>	90
<b>Accessories</b>	N.A.
<b>Notes</b>	N.A.
<b>Mounting tips</b>	Not suitable for every application, please check

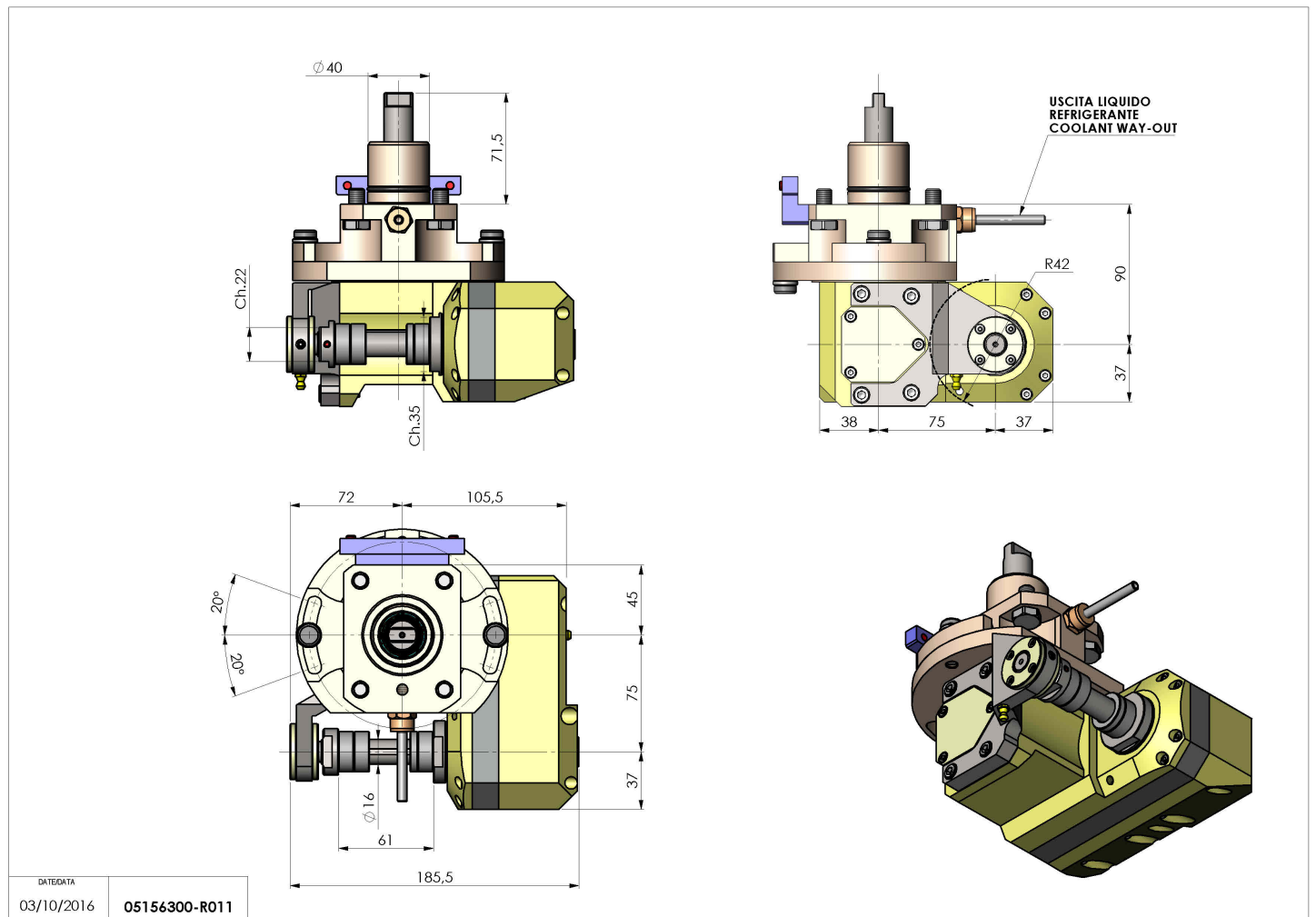

Always check live tool dimensions on the turret



DATE/DATE: 03/10/2016  
05156300-R011

Subject to technical changes