



05112600 - LT-S VDI40 ER32F H67 117 HA

Type	LT-S Tool holder straight
Mounting	VDI 40
Tool output	Collet nut ER 32 F - internal nut
Coolant	External coolant
Direction of rotation	r1  r2 
Max speed [rpm]	6000
Max torque [Nm]	63
Ratio	1:1
H [mm]	67
Accessories	
Notes	Soon out of stock. Replaced by cod. 05112000
Mounting tips	Not suitable for every application, please check

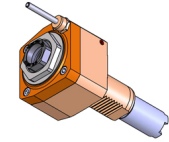

ATTENZIONE: VERIFICARE L'ORIENTAMENTO DELLA DENTATURA VDI

Always check live tool dimensions on the turret

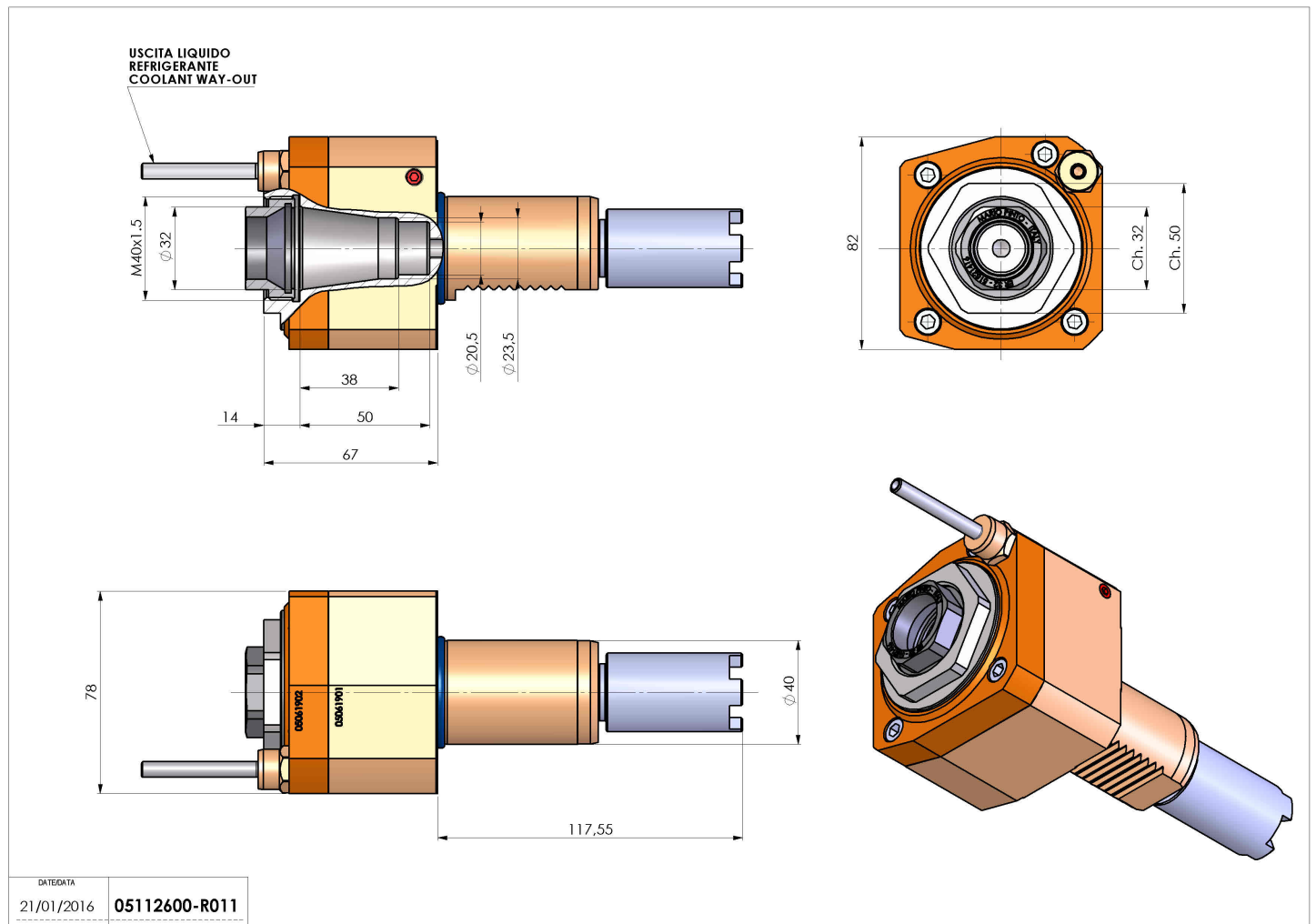

DATE/DATE	05112600-R011
21/01/2016	

Subject to technical changes