

05112100 - LT-S VDI40 ER32F RF H74 117 HA

Type	LT-S Tool holder straight
Mounting	VDI 40
Tool output	Collet nut ER 32 F - internal nut
Coolant	Internal coolant
Direction of rotation	r1 r2
Max speed [rpm]	6000
Max torque [Nm]	63
Ratio	1:1
H [mm]	74
Accessories	
Notes	N.A.
Mounting tips	Not suitable for every application, please check

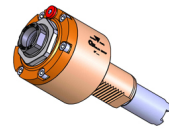

ATTENZIONE: VERIFICARE L'ORIENTAMENTO DELLA DENTATURA VDI

Always check live tool dimensions on the turret

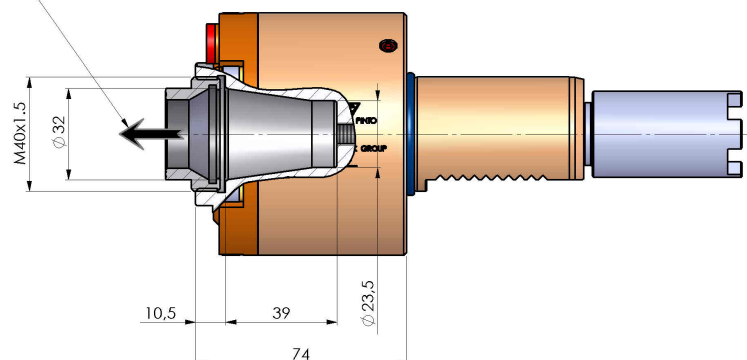

USCITA LIQUIDO
REFRIGERANTE
COOLANT WAY-OUT

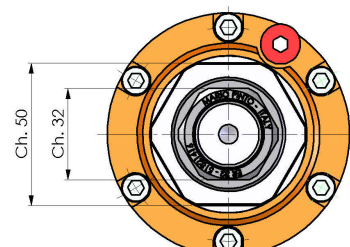

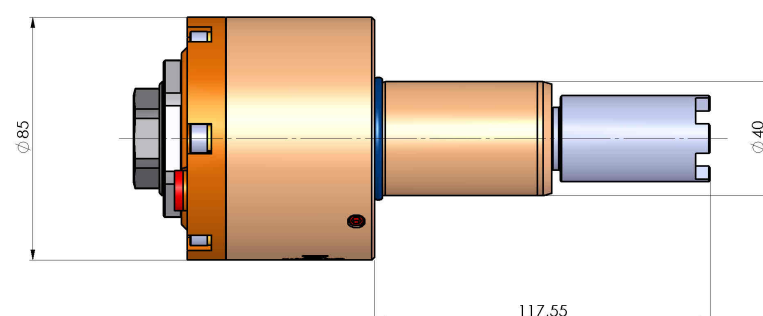

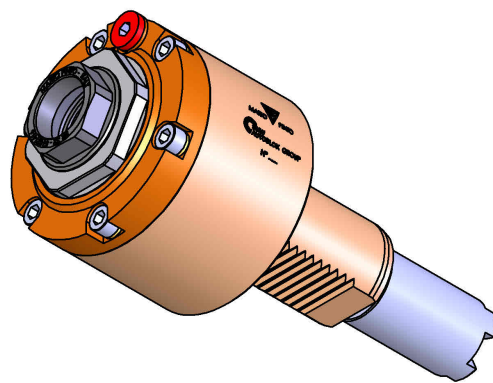

DATE/DATE

21/01/2016

05112100-R011

Subject to technical changes