

## 05110700 - LT-A VDI40 DIN138-22 R H75

|                       |  |
|-----------------------|--|
| Type                  | LT-A<br>Tool holder angle 90°                    |
| Mounting              | VDI 40   |
| Tool output           | Shell-Mill DIN138 22                             |
| Coolant               | External coolant                                 |
| Direction of rotation | r1 ↻ r2 ↻  |
| Max speed [rpm]       | 6000   |
| Max torque [Nm]       | 63   |
| Ratio                 | 1:1  |
| H [mm]                | 75   |
| H1 [mm]               | 38   |
| Accessories           | N.A.   |
| Notes                 | N.A.   |
| Mounting tips         | Not suitable for every application, please check |

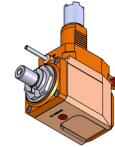

**ATTENZIONE: VERIFICARE L'ORIENTAMENTO DELLA DENTATURA VDI**

Always check live tool dimensions on the turret

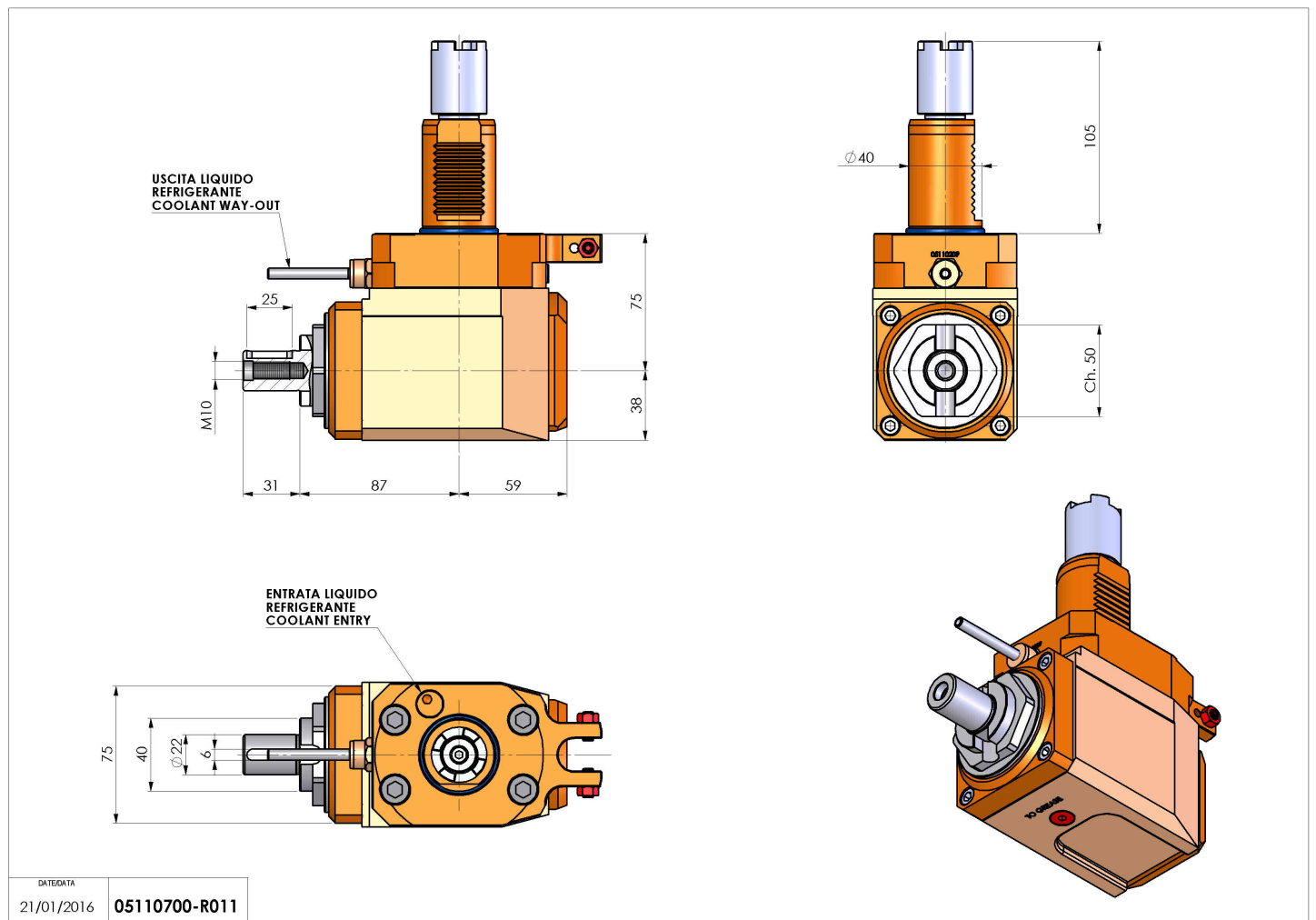

|            |               |
|------------|---------------|
| DATE/DATE  | 05110700-R011 |
| 21/01/2016 |               |

Subject to technical changes