

# 05067300 - LT-S2 VDI30 ER11 I25 H85 1:10K

<b>Type</b>	LT-S2 Tool holder double straight
<b>Mounting</b>	VDI 30
<b>Tool output</b>	Collet nut ER 11
<b>Coolant</b>	External coolant
<b>Direction of rotation</b>	r1 ↻ r2 ↻ r3 ↻
<b>Max speed [rpm]</b>	6000
<b>Max torque [Nm]</b>	10
<b>Ratio</b>	1:1
<b>H [mm]</b>	85
<b>Accessories</b>	N.A.
<b>Notes</b>	N.A.
<b>Mounting tips</b>	Not suitable for every application, please check

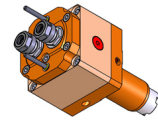

**ATTENZIONE: VERIFICARE L'ORIENTAMENTO DELLA DENTATURA VDI**

Always check live tool dimensions on the turret

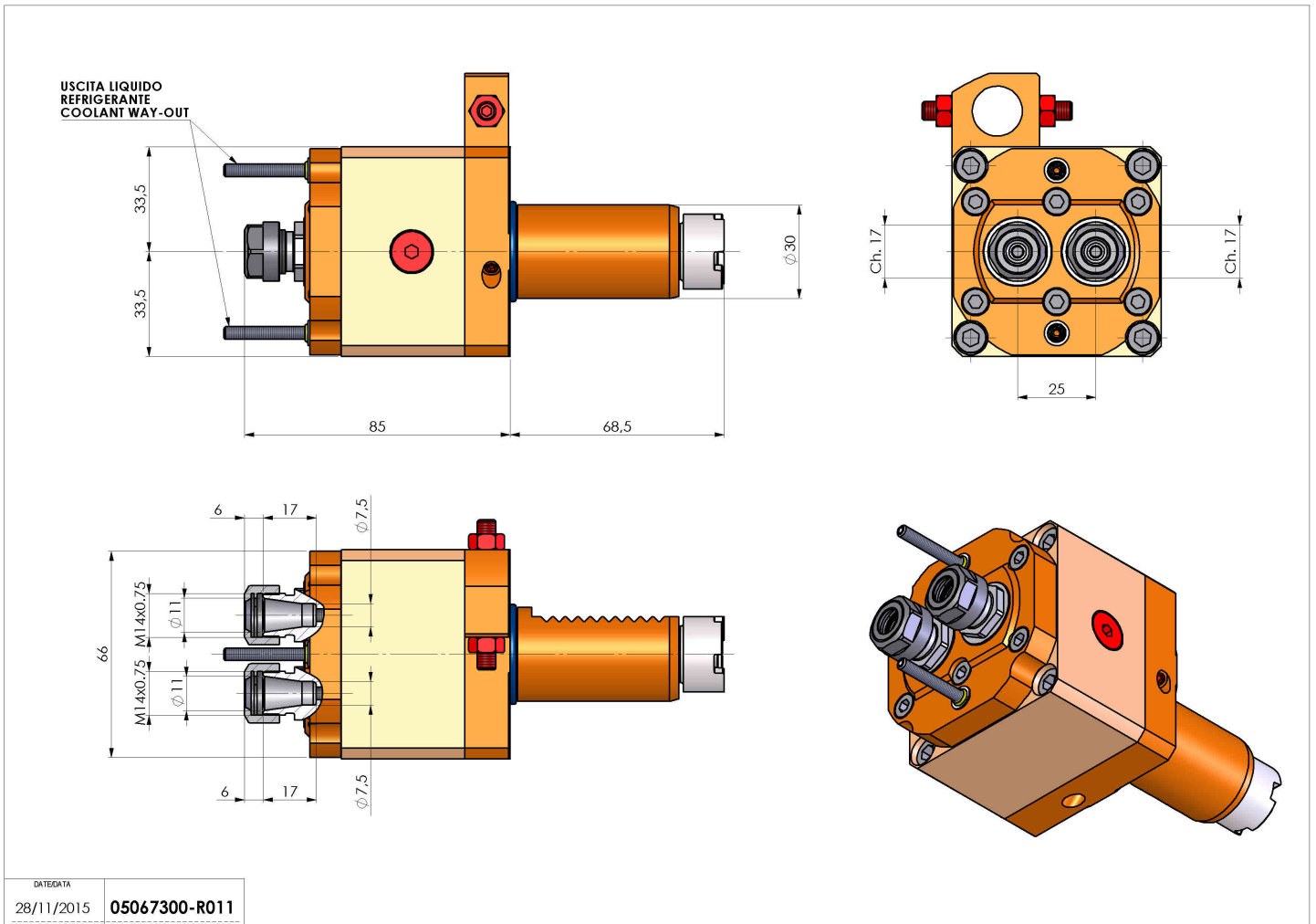

DATE/GATE  
28/11/2015 05067300-R011

Subject to technical changes