

05046500 - LT-A D60 ER32F-32F LR2:1H90 MS

Type	LT-A DBL Tool holder double angle 90°
Mounting	CYLINDRICAL SHANK 60
Tool output	Collet nut ER 32 F - internal nut
Coolant	External coolant
Direction of rotation	r1 ↻ r2 ↻ r3 ↻
Max speed [rpm]	in 10000 / out 5000
Max torque [Nm]	in 60 / out 120
Ratio	2:1
H [mm]	90
H1 [mm]	37,5
Accessories	N.A.
Notes	N.A.
Mounting tips	Not suitable for every application, please check

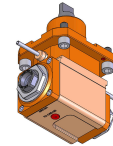

Always check live tool dimensions on the turret

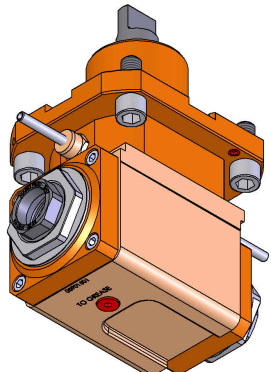
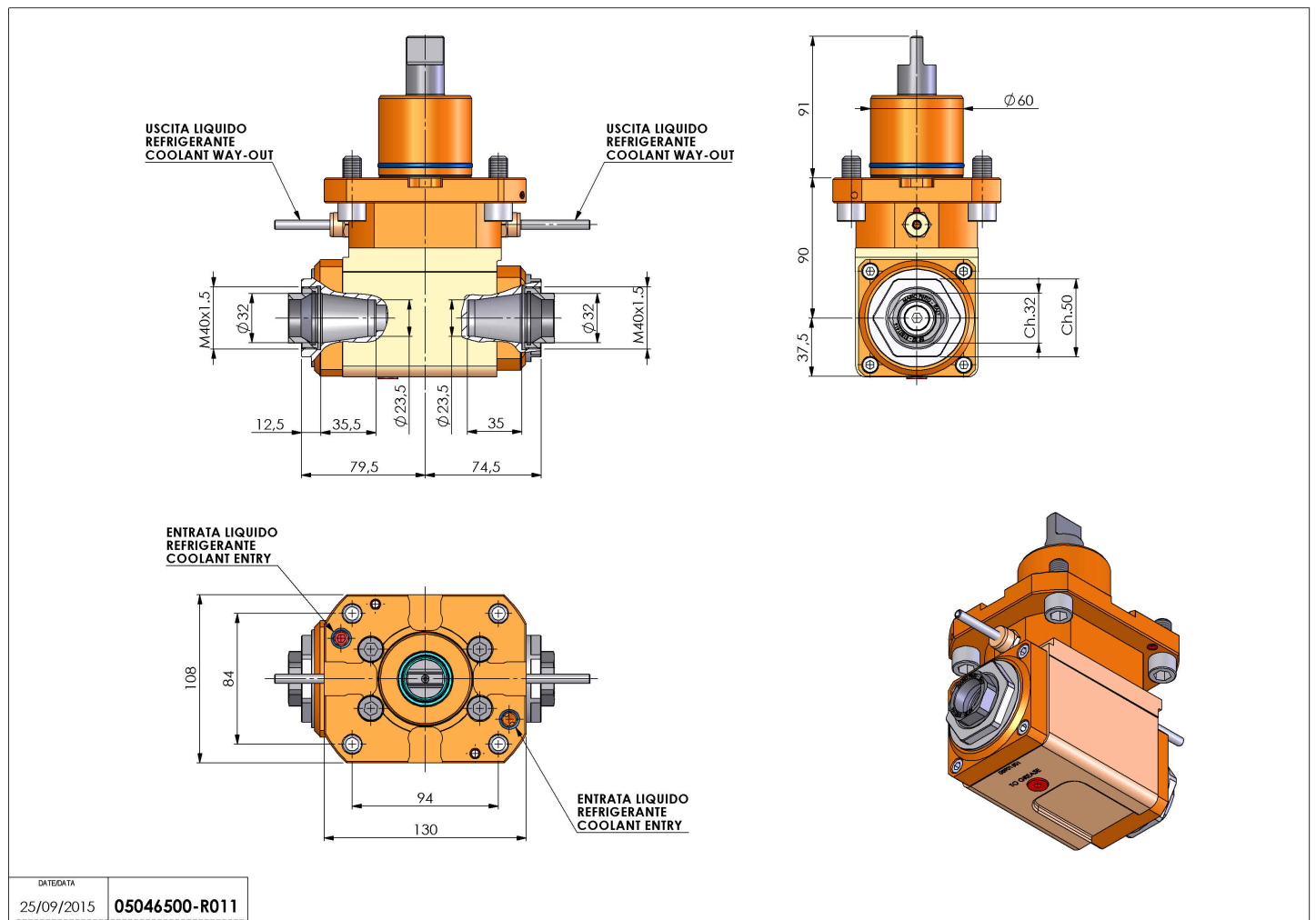

DATE/DATA	05046500-R011
25/09/2015	

Subject to technical changes