



05036000 - LT-S D68 ER32 H85 TWJ

Type	LT-S Tool holder straight
Mounting	CYLINDRICAL SHANK 68
Tool output	Collet nut ER 32
Coolant	External coolant
Direction of rotation	r1  r2 
Max speed [rpm]	6000
Max torque [Nm]	63
Ratio	1:1
H [mm]	85
Accessories	
Notes	N.A.
Mounting tips	Not suitable for every application, please check



Always check live tool dimensions on the turret

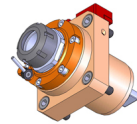
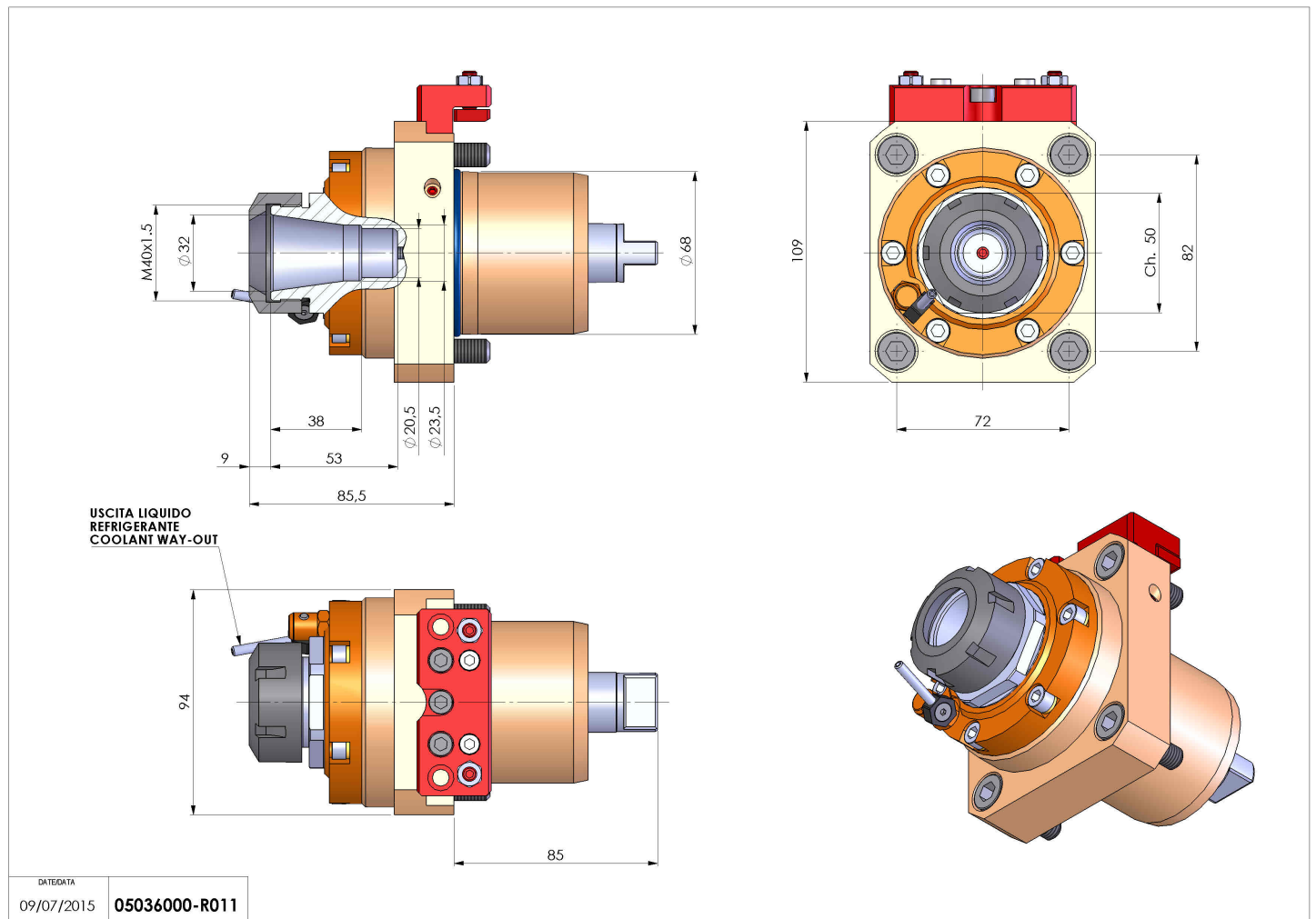

Subject to technical changes