

05026000 - LT-A VDI30 ER25 R 1:2 H75 TZ

Type	LT-A Tool holder angle 90°
Mounting	VDI 30
Tool output	Collet nut ER 25
Coolant	External coolant
Direction of rotation	r1 ↻ r2 ↻
Max speed [rpm]	in 6000 / out 12000
Max torque [Nm]	in 30 / out 15
Ratio	1:2
H [mm]	75
H1 [mm]	32,5
Accessories	N.A.
Notes	N.A.
Mounting tips	Not suitable for every application, please check

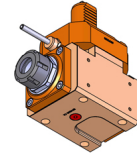

ATTENZIONE: VERIFICARE L'ORIENTAMENTO DELLA DENTATURA VDI

Always check live tool dimensions on the turret

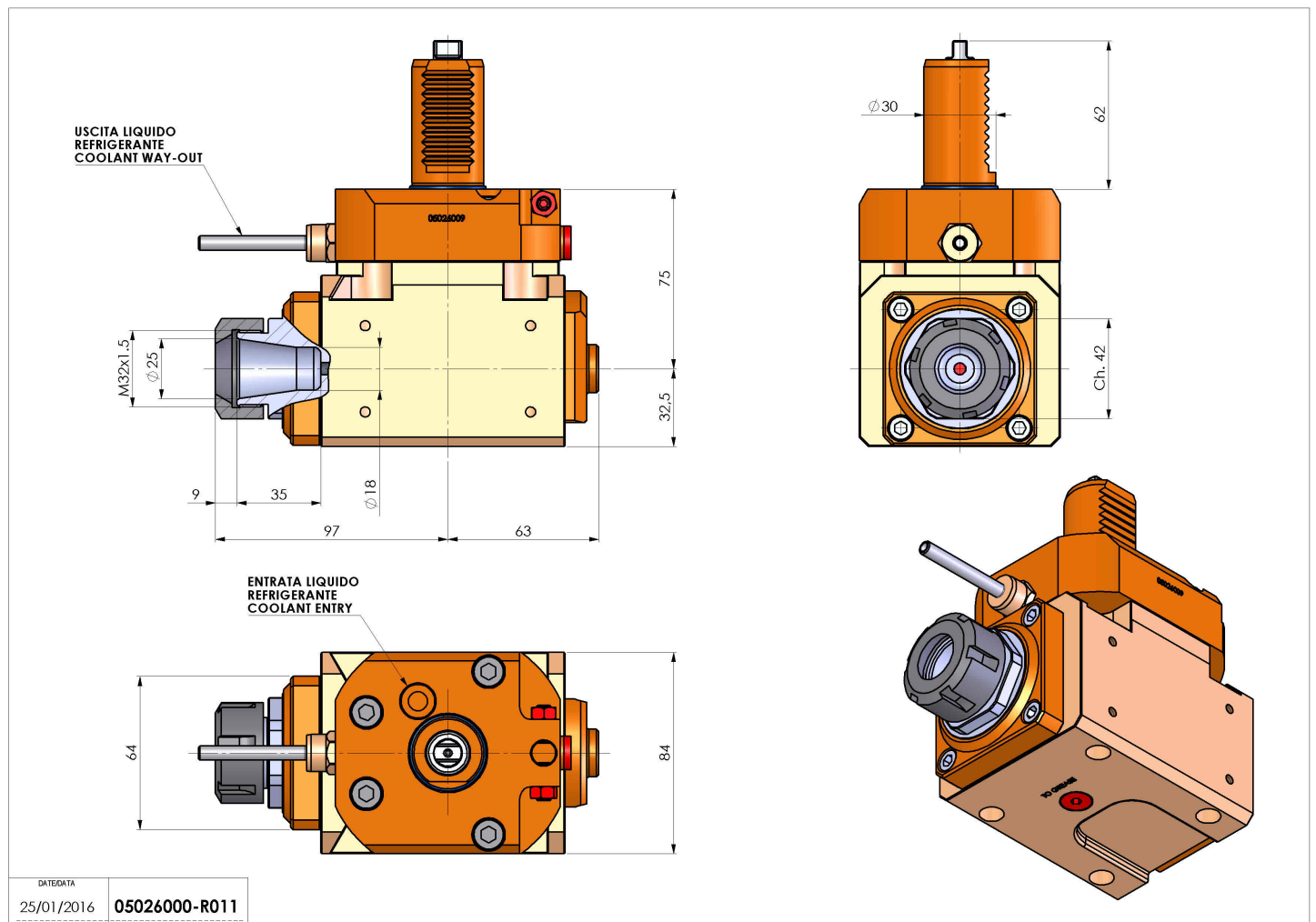

Subject to technical changes