

05011700 - LT-S D55 DIN138-16 H52 NK

Type	LT-S Tool holder straight
Mounting	CYLINDRICAL SHANK 55
Tool output	Shell-Mill DIN138 16
Coolant	External coolant
Direction of rotation	r1 r2
Max speed [rpm]	6000
Max torque [Nm]	63
Ratio	1:1
H [mm]	52
Accessories	
Notes	N.A.
Mounting tips	Not suitable for every application, please check

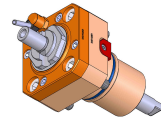

Always check live tool dimensions on the turret

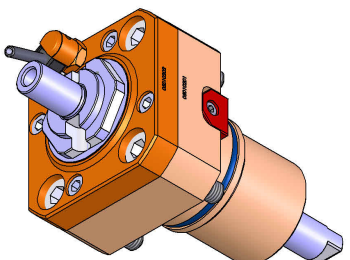
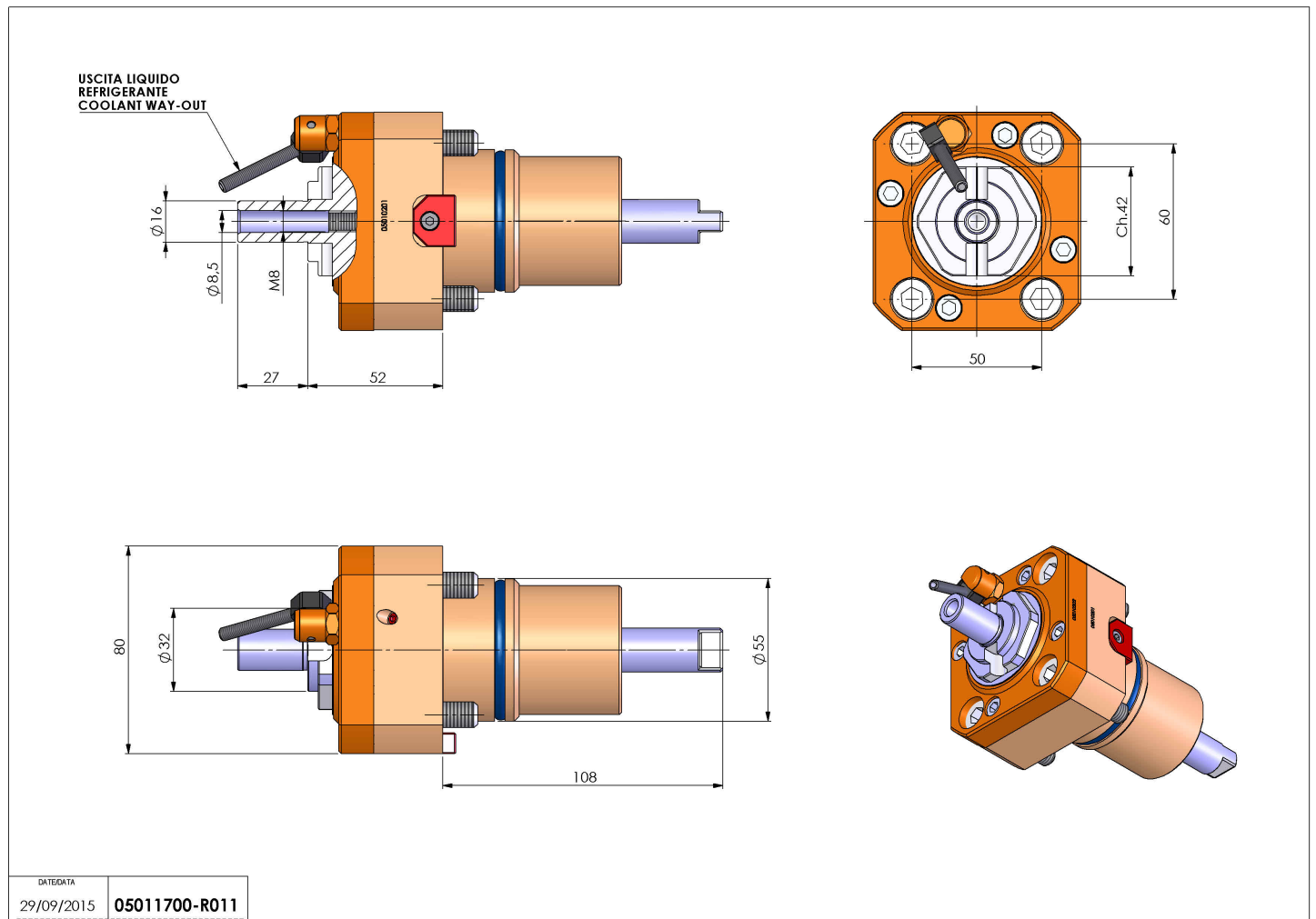

DATE/DATA	
29/09/2015	05011700-R011

Subject to technical changes